

Lafferty Equipment Manufacturing, Inc. Installation & Operation Instructions

Model # 969712 · Model 10 SS Bypass 2-Way Airless Foamer / Sprayer

REQUIREMENTS

Water Temperature	up to 180°F
Pressure Washer	2.2 - 3.4 GPM
Discharge Hose	3/8" ID minimum Up to 200' length

OPTIONS

Stainless Steel Hose Racks	
Large Stainless Steel Hose Rack	# 224150
Safe Flow Lid™ for 1 Gallon Jugs	
Lid, Suction Tube, and Strainer	# 709101
Pressure Washer Hose & Trigger Gun	
HP 3/8" x 50' Hose & Trigger Gun Kit	# 807069
Inlet Jumper Hose	
Hose, 3/8" x 6', High Pressure	# 195006
Hose, 3/8" x 15', SS, BNM, High Pressure	# 195015SS

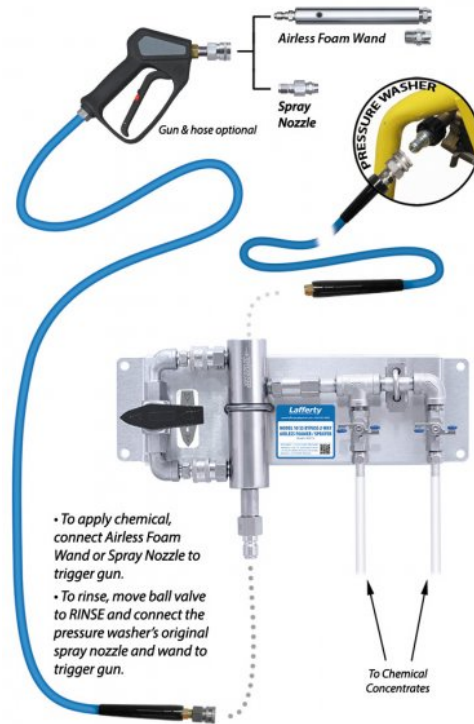

Lafferty
EQUIPMENT MANUFACTURING INC.

www.laffertyequipment.com

501-851-2820

**WARNING! READ ALL
INSTRUCTIONS BEFORE
USING EQUIPMENT!**



OVERVIEW

Designed for 2.2–3.4 GPM pressure washers. The Model 10 SS Bypass 2-Way Airless Foamer / Sprayer is a wash/rinse system for quickly diluting and applying two chemicals and rinsing through the same hose. This venturi unit draws and blends two separate chemicals or two different concentrations of the same chemical into the water stream to create an accurately diluted solution. The solution then flows through the hose and gun to the airless foam wand which draws in atmospheric air to create and project wet, clinging foam on to surfaces up close or at distances up to 20 feet with interchangeable fan and zero degree nozzles. Quick connect the fan pattern sprayer nozzle to apply non-foaming chemicals. Open the bypass ball valve to rinse at full volume and pressure.

SAFETY & OPERATIONAL PRECAUTIONS

- For proper performance do NOT modify, substitute nozzle, hose diameter or length.
- Manufacturer assumes no liability for the use or misuse of this unit.
- Wear protective clothing, gloves and eye wear when working with chemicals.
- Always direct the discharge away from people and electrical devices.
- Follow the chemical manufacturer's safe handling instructions.

TO INSTALL (REFER TO DIAGRAM ON NEXT PAGE)

If you are connecting to a potable water supply follow all local codes for backflow prevention.

1. Mount the unit to a suitable surface above the chemical supply to prevent siphoning.
2. Connect hose(s) as shown in the diagram.
3. Flush any new plumbing of debris before connecting water.
4. Connect water supply. Install a water filter if water piping is older or has known contaminants.

Set the chemical dilution ratio by threading one of the color coded metering tips into each chemical check valve. See chemical labels for dilution ratio recommendation or consult your chemical supplier.

- For the strongest dilution ratio do NOT install a colored metering tip.
- The dilution ratios in the metering tip chart are based on water thin chemicals with a viscosity of 1CPS.
- Thicker chemicals will require a larger tip than the ratios shown in the chart.
- Application results will ultimately determine final tip color.
- Select the tip color that is closest to your desired chemical strength and thread it into the tip holder. **DO NOT OVER-TIGHTEN.**
- Push the chemical tube over the check valve barb and place the suction tube in the chemical concentrate.
- If necessary, cut suction tube(s) to length before attaching suction strainer.

TO OPERATE

TO FOAM OR SPRAY

1. Remove the rinse nozzle and quick connect the foam wand or the spray nozzle to your trigger gun as shown in the diagram. If your trigger gun doesn't have quick disconnects you will have to install them.
2. Turn the by-pass ball valve to the "foam" position.
3. Open 1-chemical ball valve.
4. Hold the trigger gun firmly and direct the discharge in a safe direction. Pull the trigger and begin application.
5. Make final metering tip adjustments based on application results. Try the next larger sized metering tip until the results are acceptable.
6. Repeat step 3 for additional chemicals

TO RINSE

1. When foaming/spraying is completed, release the trigger.
2. Replace the airless foam wand or low pressure spray nozzle with the original pressure washer rinse nozzle or the included rinse nozzle (provided with select models).
3. Close the chemical ball valves, and open the by-pass ball valve.
4. Rinse the work surface as you normally would and rinse before the chemical dries.
5. If the unit will not be used for a period of time it is BEST to draw fresh water through the pick up tube(s) to prevent chemical from drying inside the components.

METERING TIP SELECTION

METERING TIP COLOR	DILUTION RATIO AT GPM	
	2.5	3.0
Brown	571:1	686:1
Clear	364:1	436:1
Bright Purple	232:1	278:1
White	149:1	179:1
Pink	109:1	131:1
Corn Yellow	83:1	100:1
Dark Green	66:1	79:1
Orange	55:1	67:1
Gray	53:1	64:1
Light Green	46:1	55:1
Med. Green	40:1	48:1
Clear Pink	34:1	41:1
Yellow Green	28:1	33:1
Burgundy	27:1	32:1
Pale Pink	23:1	28:1
Light Blue	21:1	25:1
Dark Purple	18:1	21:1
Navy Blue	13:1	15:1
Clear Aqua	11:1	13:1
Black	6:1	8:1
No Tip Ratio Up To:	5:1	7:1

The dilution ratios above are approximate values. Due to chemical viscosity, actual dilution ratios may vary.

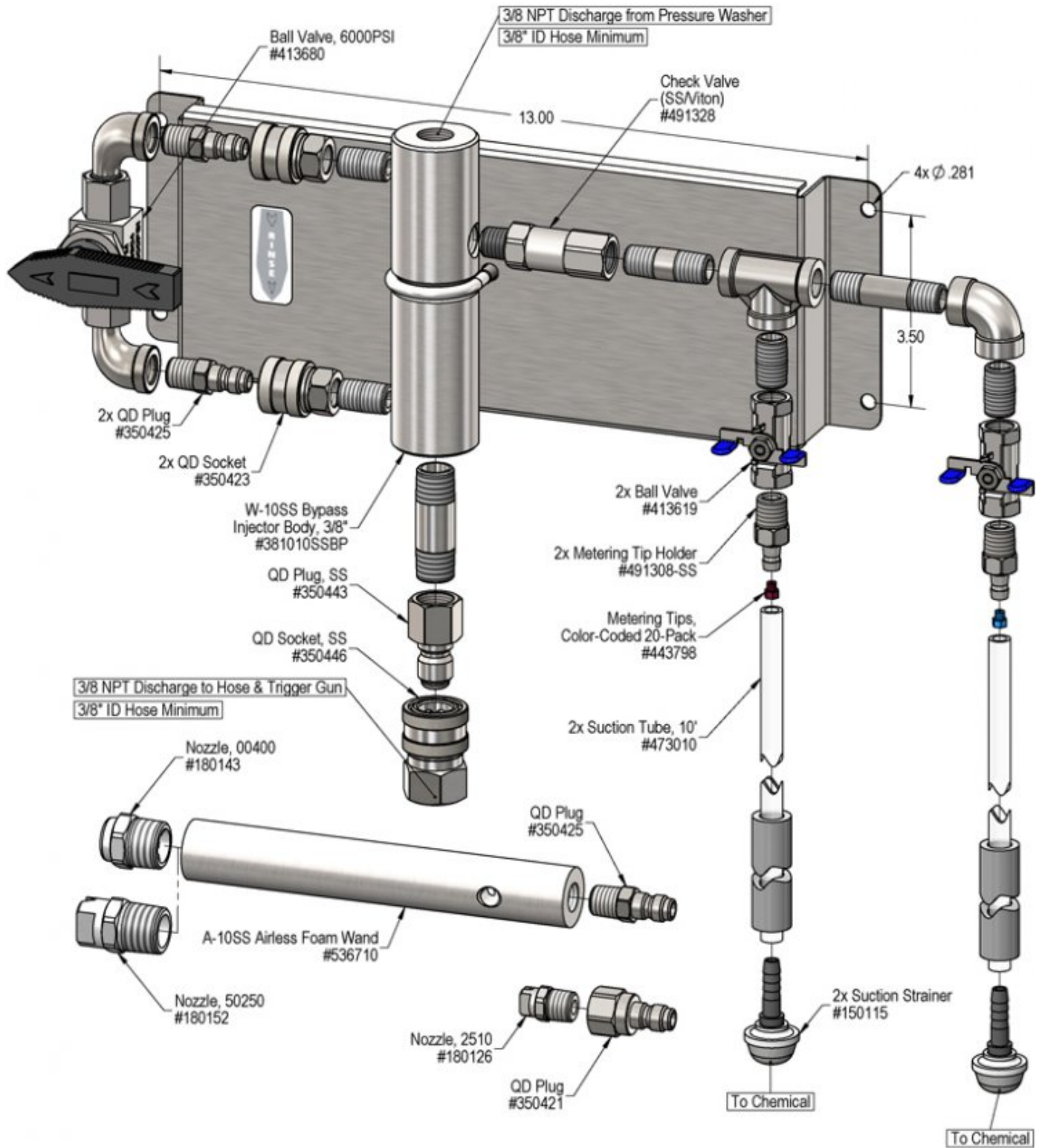

Troubleshooting Guide

Problem	Possible Cause / Solution	
	Startup	Maintenance
A) Unit will not draw chemical.	1, 2, 3, 7	8, 9, 10, 11, 12, 13
B) Does not foam properly	1, 4, 5, 7	8, 9, 11, 12
C) Using too much chemical	6	

Possible Cause / Solution	
Startup	Maintenance
<ol style="list-style-type: none"> 1. Water volume too low <ul style="list-style-type: none"> ◦ See requirements. 2. Water inlet clogged <ul style="list-style-type: none"> ◦ Clean the water inlet. DO NOT DRILL OUT 3. Hose size too small <ul style="list-style-type: none"> ◦ MUST be 3/8" ID hose, minimum 4. Ensure chemical is recommended for foaming and/or the application <ul style="list-style-type: none"> ◦ Refer to chemical manufacturer. 5. Dilution too weak / Chemical is very thick. <ul style="list-style-type: none"> ◦ Install larger metering tip or remove metering tip. 6. Dilution too strong / No metering tip installed or wrong metering tip installed <ul style="list-style-type: none"> ◦ Install a metering tip or install a smaller metering tip ◦ If the exact dilution ratio cannot be achieved with metering tips, pre-dilute the chemical with water before drawing it into the injector for final dilution and application 7. Hose too long <ul style="list-style-type: none"> ◦ Use a shorter discharge hose to alleviate back pressure on the injector ◦ The allowable length of hose varies based on individual pressure washers and equipment setups. 200' max recommended hose length between injector and nozzle. Longer hose could affect dilution ratios. 	<ol style="list-style-type: none"> 8. Chemical check valve stuck, clogged, loose or failed <ul style="list-style-type: none"> ◦ Clean, tighten or rebuild. 9. Chemical strainer or metering tip blocked <ul style="list-style-type: none"> ◦ Clean or replace chemical strainer and/or metering tip. 10. Chemical tube stretched out where tube slides over check valve or pin hole/cut in chemical tube (sucking air in) which reduces chemical intake. Chemical tube not immersed in chemical or depleted. <ul style="list-style-type: none"> ◦ Cut off end of tube, replace tube or immerse tube in chemical 11. Discharge nozzle is wrong size <ul style="list-style-type: none"> ◦ Install correct nozzle (see parts drawing) ◦ Use only provided nozzles/wands for chemical application 12. Chemical build-up or hard water scale may have formed in the foam wand or injector body causing poor or no chemical pick-up <ul style="list-style-type: none"> ◦ Follow Preventive Maintenance instructions below, using hot water and/or descaling acid. When there is no draw at all, carefully remove inlet fitting and chemical check valve. Soak injector body and or foam wand in de-scaling acid. 13. Bypass ball valve open (Bypass models only) <ul style="list-style-type: none"> ◦ Close bypass valve.

PREVENTIVE MAINTENANCE: When the unit will be out of service for extended periods, place chemical tube(s) in water and flush the chemical out of the unit to help prevent chemical from drying out and causing build-up. Periodically check and clean chemical strainer and replace if missing.

