

Lafferty Equipment Manufacturing, LLC Installation & Operation Instructions

Model # 985450 · 5-Way Ball Valve Mixing Station

REQUIREMENTS

Chemical Concentrate

Water

Temperature	up to 160°F
Pressure	25-125 PSI
Supply Line	1/2" Minimum

Flow

High Flow (Black Injector)	4.0 - 7.3 GPM
Low Flow (White Injector)	1.9 - 3.4 GPM
Bottle Fill (Blue Injector)	0.6 - 1.0 GPM

OPTIONS

Stainless Steel Jug Racks

1 Gallon Round/Square	# 224200
1 Gallon Round/Square Locking	# 224200-L
2 ½ Gallon (8 ½" x 10 ½")	# 224210
5 Gallon Round/Square Locking (12" x 12")	# 224214
5 Gallon Round/Square (12" x 12")	# 224215

Safe Flow Lid™ for 1 Gallon Jugs

Lid, Suction Tube, and Strainer	# 709101
---------------------------------	----------

Alternate Chemical Check Valve - EPDM Standard

Check Valve, Chemical, PP, 1/4" (Viton)	# 491402
-----------------------------------------	----------

Jumper Hose with GH Fittings (10')

GH Hose, Blue, 1/2" x 10'	# 804410B
---------------------------	-----------

Red, Blue, Green & Yellow Ball Valve Handles

413511RED, 413511BLU, 413511GRN, 413511YLW

WEIGHT & DIMENSIONS

Single Package

Shipping Weight	14 lbs.
Shipping Dimensions	20" x 18" x 5"



Lafferty
EQUIPMENT MANUFACTURING LLC

www.laffertyequipment.com

501-851-2820

**WARNING! READ ALL
INSTRUCTIONS BEFORE
USING EQUIPMENT!**



OVERVIEW

The 5-Way Ball Valve Mixing Station is an ASSE 1055 certified chemical proportioner that accurately dilutes chemicals to the required ratios and dispenses into any size container. This venturi injection system uses city water pressure (25 - 125 PSI) to draw and blend chemical concentrate into the water stream and precision metering tips to set the dilution ratio for each valve. Ball valve activation allows for hands-free dispensing. Choose a factory-set flow rate for each ball valve at the time of order (Bottle Fill, Low Flow, High Flow).

SAFETY & OPERATIONAL PRECAUTIONS

- For proper performance do NOT modify hose diameter or length.
- Do NOT attempt to install a discharge ball valve.
- Manufacturer assumes no liability for the use or misuse of this unit.
- Wear protective clothing, gloves and eye wear when working with chemicals.
- Always direct the discharge away from people and electrical devices.
- Follow the chemical manufacturer's safe handling instructions.
- Never use chemicals that could be dangerous if accidentally mixed.



- This device is certified to meet ASSE Standard 1055 regarding Chemical Dispensing Systems with Integral Backflow Prevention.
- **WARNING:** Contamination of your potable water supply can occur without proper backflow prevention. Follow all local codes for backflow prevention when connecting to a potable water supply.

Installation for Devices Plumbed to a Faucet with a Vacuum Breaker

- In cases where an installation involves a water source coming from a faucet with an integrated vacuum breaker device conforming to ASSE 1001 or ASSE 1011, a pressure bleed device conforming to IAPMO PS-104 shall be used to protect the vacuum breaker device.
- The purpose is so that continuous pressure does not adversely affect the vacuum breaker device upstream of the pressure bleed device. This also protects against a cross-connection between hot and cold water migration by encouraging the user to turn off the water supply at the faucet.

TO INSTALL (REFER TO DIAGRAM ON NEXT PAGE)

1. Attach discharge tubes (see diagram). Discharge tubes can be cut to length as needed.
 - *NOTE: Do not install a shutoff or flow restriction device on end of discharge hose (valve, trigger, nozzle, etc.) This unit is designed for open flow dispensing.*
2. Mount to suitable surface above the chemical to prevent siphoning. Use suitable fasteners based on the mounting surface and system weight. See diagram for mounting hole size and spacing.
3. Select and install metering tips and suction tubes by following instructions below TO SET DILUTION RATIO.
4. To prevent blocking the small orifices inside the injector, flush debris from new plumbing before connecting. If water piping is older and has known contaminants, install a water filter. Always use the included washer with screen on the unit inlet.
5. Connect water supply.
6. Immerse chemical suction tubes with strainers into container(s) of chemical concentrate.

TO SET DILUTION RATIO, thread a color-coded metering tip into each tip holder. See chemical labels for dilution ratio recommendation or consult your chemical supplier.

- For the strongest dilution ratio do NOT install a colored metering tip.
- The dilution ratios in the metering tip chart are based on water thin chemicals with a viscosity of 1CPS. Thicker chemicals will require a larger tip than the ratios shown in the chart.
- Chart shows ratios at 40 PSI water pressure. Actual water pressure is shown on unit gauge during operation. Adjust metering tip selection based on actual water pressure using the online [Metering Tip Calculator](#) or the math formula shown in the chart.
- Select and thread the tip color that is closest to your desired chemical strength into the tip holder. **DO NOT OVER-TIGHTEN**
- Application results will ultimately determine final tip color selection.
- Push the chemical tubes over the tip holders and place the strainer in the chemical concentrate.
- If necessary, cut suction tube(s) to length.

If a leaner solution than the maximum shown in the chart is required, it will be necessary to use one proportioner to pre-dilute the concentrate, and a second to dilute the resulting solution to the required final ratio. If this [Double Dilution](#) procedure is required, choose two metering tips whose ratios, when multiplied together, result in a ratio that is as close as possible to the required final ratio. *Example: For two "Bottle Fill" Mixing Station valves with 40 PSI water pressure, use a White Tip (37:1) and a Corn Yellow Tip (21:1) to achieve a final solution ratio of 777:1.*

TO OPERATE

1. Hold the discharge tube inside the container to be filled, do not release it, and completely open the inlet ball valve. For units with multiple valves, only open one ball valve at a time.
2. When container is filled to the desired level, close the ball valve and keep the discharge tube in the container until it completely drains before removing it.
3. Make final metering tip adjustments based on application results. Try the next larger or smaller sized metering tip until the results are acceptable.

METERING TIP SELECTION

METERING TIP COLOR	OZ/MIN	DILUTION RATIO @ 40 PSI		
		HIGH FLOW	LOW FLOW	BOTTLE FILL
Brown	0.56	1031:1	480:1	142:1
Clear	0.88	656:1	305:1	90:1
Bright Purple	1.38	418:1	195:1	58:1
White	2.15	269:1	125:1	37:1
Pink	2.93	197:1	92:1	27:1
Corn Yellow	3.84	150:1	70:1	21:1
Dark Green	4.88	118:1	55:1	16:1
Orange	5.77	100:1	47:1	14:1
Gray	6.01	96:1	45:1	13:1
Light Green	7.01	82:1	38:1	11:1
Med. Green	8.06	72:1	33:1	10:1
Clear Pink	9.43	61:1	29:1	8:1
Yellow Green	11.50	50:1	23:1	7:1
Burgundy	11.93	48:1	23:1	7:1
Pale Pink	13.87	42:1	19:1	6:1
Light Blue	15.14	38:1	18:1	5:1
Dark Purple	17.88	32:1	15:1	4:1
Navy Blue	25.36	23:1	11:1	3:1
Clear Aqua	28.60	20:1	9:1	3:1
Black	50.00	12:1	5:1	—
No Tip Ratio Up To:		4.8:1	3.5:1	1.7:1
The dilution ratios above are approximate values. Due to chemical viscosity, actual dilution ratios may vary.				
FORMULA				
GPM × 128 ÷ Desired Dilution Ratio = oz/min				
<ul style="list-style-type: none"> • See Unit Flow Rates chart for GPM • Use 20 for 20:1 dilution ratio, 30 for 30:1, etc. • Match calculated ounces per minute (oz/min) to nearest oz/min in Metering Tip Selection chart. 				

UNIT FLOW RATES

PSI	GPM		
	HIGH FLOW	LOW FLOW	BOTTLE FILL
35	4.22	1.96	0.58
40	4.51	2.10	0.62
50	5.04	2.35	0.69
60	5.52	2.57	0.76
70	5.97	2.78	0.82
80	6.38	2.97	0.88
90	6.77	3.15	0.93
100	7.13	3.32	0.98
110	7.48	3.48	1.03
120	7.81	3.64	1.07
125	7.97	3.71	1.10

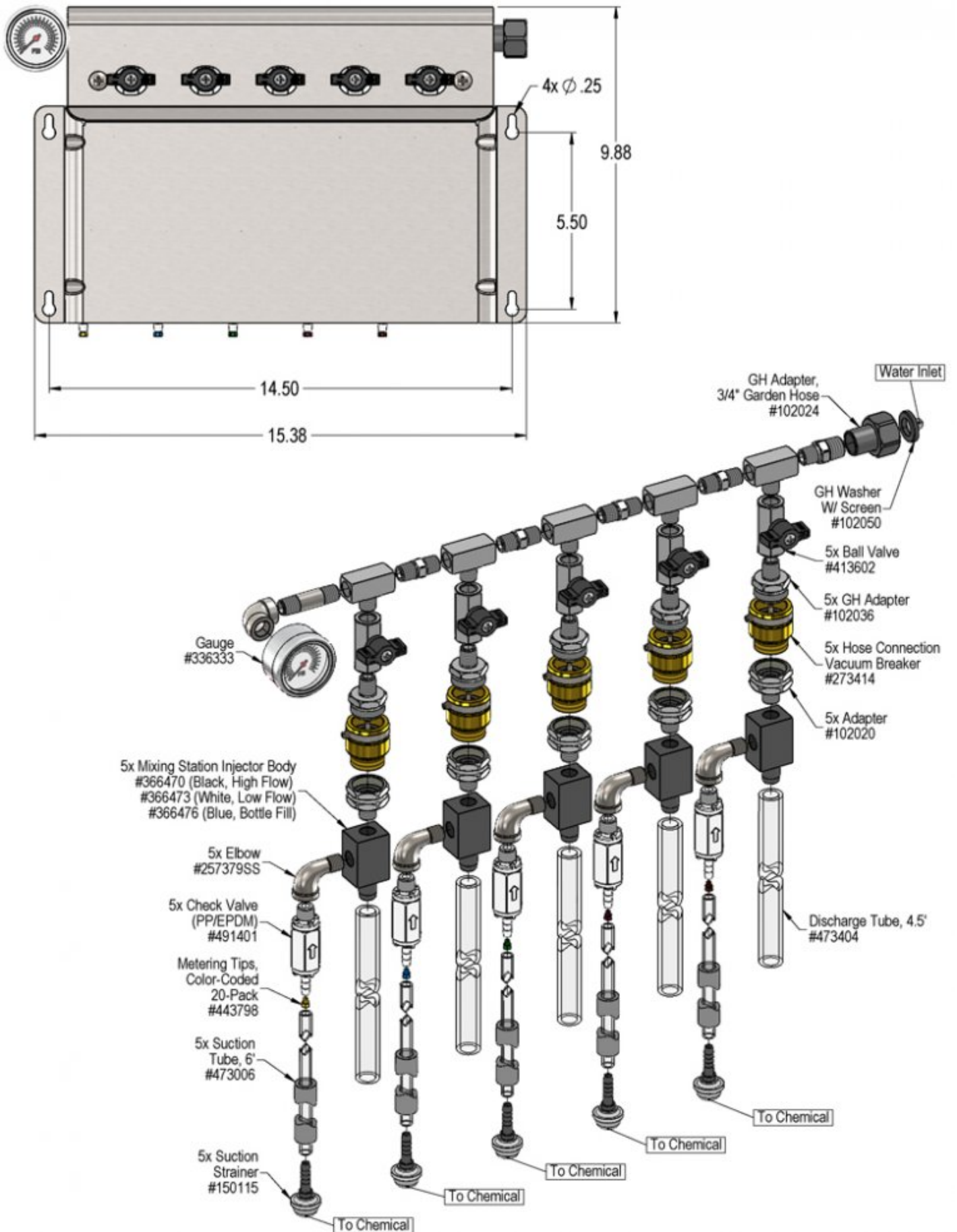

Troubleshooting Guide

Problem	Possible Cause / Solution	
	Startup	Maintenance
A) Unit will not draw chemical. B) Dilution too weak. C) Dilution too strong D) Water backing up into chemical container. E) Vacuum breaker constantly dripping / leaking.	1, 2, 3 4 5	6, 7, 8, 9, 10, 11 11 8 12, 13

Possible Cause / Solution	
Startup	Maintenance
<ol style="list-style-type: none"> 1. Water pressure too low or water temperature too high <ul style="list-style-type: none"> ◦ See requirements. 2. Ball valve not completely open <ul style="list-style-type: none"> ◦ Completely open the ball valve. 3. Chemical tube not immersed in chemical or chemical depleted <ul style="list-style-type: none"> ◦ Immerse tube or replenish. 4. Metering tip too small <ul style="list-style-type: none"> ◦ Install larger metering tip. 5. No metering tip installed or metering tip too large <ul style="list-style-type: none"> ◦ Install smaller metering tip. 	<ol style="list-style-type: none"> 6. Water inlet strainer screen clogged <ul style="list-style-type: none"> ◦ Disconnect water and clean the screen. 7. Chemical strainer or metering tip partially blocked <ul style="list-style-type: none"> ◦ Clean or replace chemical strainer and/or metering tip. 8. Check valve stuck or failed <ul style="list-style-type: none"> ◦ Clean or replace. 9. Vacuum leak in chemical pick-up connections <ul style="list-style-type: none"> ◦ Tighten the connection. 10. Chemical tube stretched out where tube slides over metering tip holder or pin hole/cut in chemical tube (sucking air in) <ul style="list-style-type: none"> ◦ Cut off end of tube or replace tube. 11. Water scale or chemical build-up may have formed in the body causing poor or no chemical pick-up <ul style="list-style-type: none"> ◦ Follow Preventive Maintenance instructions below, using hot water and/or descaling acid. When there is no draw at all, carefully remove fittings and soak entire body in descaling acid. 12. Vacuum breaker fouled or failed <ul style="list-style-type: none"> ◦ Replace vacuum breaker. ◦ Install filter on water supply line. 13. Vacuum breaker experiencing backpressure <ul style="list-style-type: none"> ◦ The vacuum breaker(s) will vent water when experiencing backpressure that cannot exist under normal operating conditions. ◦ Do not exceed maximum water pressure. See requirements. ◦ Do not modify discharge assembly, attach shutoff valve, or otherwise restrict flow from unit discharge. ◦ Descale injector body, if necessary.

PREVENTIVE MAINTENANCE: When the unit will be out of service for extended periods, place chemical tube(s) in water and flush the chemical out of the unit to help prevent chemical from drying out and causing build-up. Periodically check and clean chemical strainer and replace if missing.

