

Lafferty Equipment Manufacturing, LLC Installation & Operation Instructions

Model # 974321-TD · Timed FPV-PD Asphalt Release Sprayer

REQUIREMENTS

Ready-to-Use Chemical Solution

Compressed Air up to 4 CFM

Hose 1/2" ID x 25'

Nozzle 2520

Electric 120V

OPTIONS

Stainless Steel Hose Racks

Small Stainless Steel Hose Rack # 224145

Drum & Tote Stick Lengths & Seal Materials

Drum Stick, 33" (Viton or EPDM) # 491643 / 491643-E

Drum Stick, 48" (Viton or EPDM) # 491648 / 491648-E

Drum Stick, 54" (Viton or EPDM) # 491645 / 491645-E

Tote Stick, 33" (Viton or EPDM) # 491653 / 491653-E

Tote Stick, 48" (Viton or EPDM) # 491654 / 491654-E

Tote Stick, 54" (Viton or EPDM) # 491656 / 491656-E



Lafferty
EQUIPMENT MANUFACTURING LLC
CFS TECHNOLOGIES

www.laffertyequipment.com

501-851-2820

**WARNING! READ ALL
INSTRUCTIONS BEFORE
USING EQUIPMENT!**



OVERVIEW

The Timed FPV-PD Asphalt Release Sprayer is a chemical spray applicator for projecting ready-to-use asphalt release chemicals on to truck beds or tools to prevent asphalt from sticking. This unit features an adjustable dual-function 110V timer which controls the length of application and the delay time, which keeps the driver from immediately restarting the system. When the activation button is pressed, a Flojet air-operated, double-diaphragm pump draws pre-diluted chemical solution from a static tank and projects it through the discharge hose, trigger gun, wand and fan nozzle.

SAFETY & OPERATIONAL PRECAUTIONS

- See Additional Safety Precautions included with the Electrical Control Box Installation Information
- Always consider electrical shock hazard when working with and handling electrical equipment. If uncertain, consult an Electrician. Electrical wiring should only be done by a qualified Electrician, per Local and State Electrical Codes.
- For proper performance do NOT modify, substitute nozzle, hose diameter or length
- Manufacturer assumes no liability for the use or misuse of this unit.
- Wear protective clothing, gloves and eye-wear when working with chemicals.
- Always direct the discharge away from people and electrical devices.
- Follow the chemical manufacturer's safe handling instructions.
- DO NOT use chemicals that are not compatible with Viton diaphragms.
- For proper performance do NOT modify electrical control box.
- Manufacturer assumes no liability for the use or misuse of this unit.
- Disconnect electrical power to the control box prior to opening it.
- Remove any packing material from inside the control box before operating.

UNIT FLOW RATES

PSI	GPM
60	2.00

TO INSTALL (REFER TO DIAGRAM ON NEXT PAGE)

1. Mount the unit above solution supply level to prevent siphoning.
2. Place the strainer in the chemical solution.
3. Attach the discharge hose.
4. Attach a compressed airline to the inlet ball valve. DO NOT TURN ON
5. Air Filter/Dryer recommend.
6. Mount the push button activation control box.

SETTING THE TIMER

1. Make sure the system is not plugged in to a power source. Remove control box cover. The box contains one timer with "Run & Delay" adjustment knobs.

Run: This mode allows you to set the length of time you want the unit to run each time the operator presses the remote button. Turn the knob to set the run time (0-6 Minutes).

Delay: This mode allows you to set the length of time you want the unit to be inactive after each application. Turn the knob to set the delay time (0-6 Minutes).
2. Replace the control box cover.
3. Plug the power cord into a 120 VAC power outlet. GFI recommended.
4. Turn on your air and/or water supply (if applicable).
5. Push the remote button to activate the timer and make any last adjustments needed.
6. The unit is ready for operation. The run mode will activate the unit for the preset run time, turn off, and will not reactivate until the time runs out on the delay mode. Then the unit will reset.

TO SPRAY

1. With the trigger gun in hand push the remote button.
2. Pull the trigger on the trigger gun to begin application.
3. The run timer will activate the unit for the preset run time and then turn the unit off. The delay timer will prevent the unit from activating until the preset delay time runs out, then the button will reset.

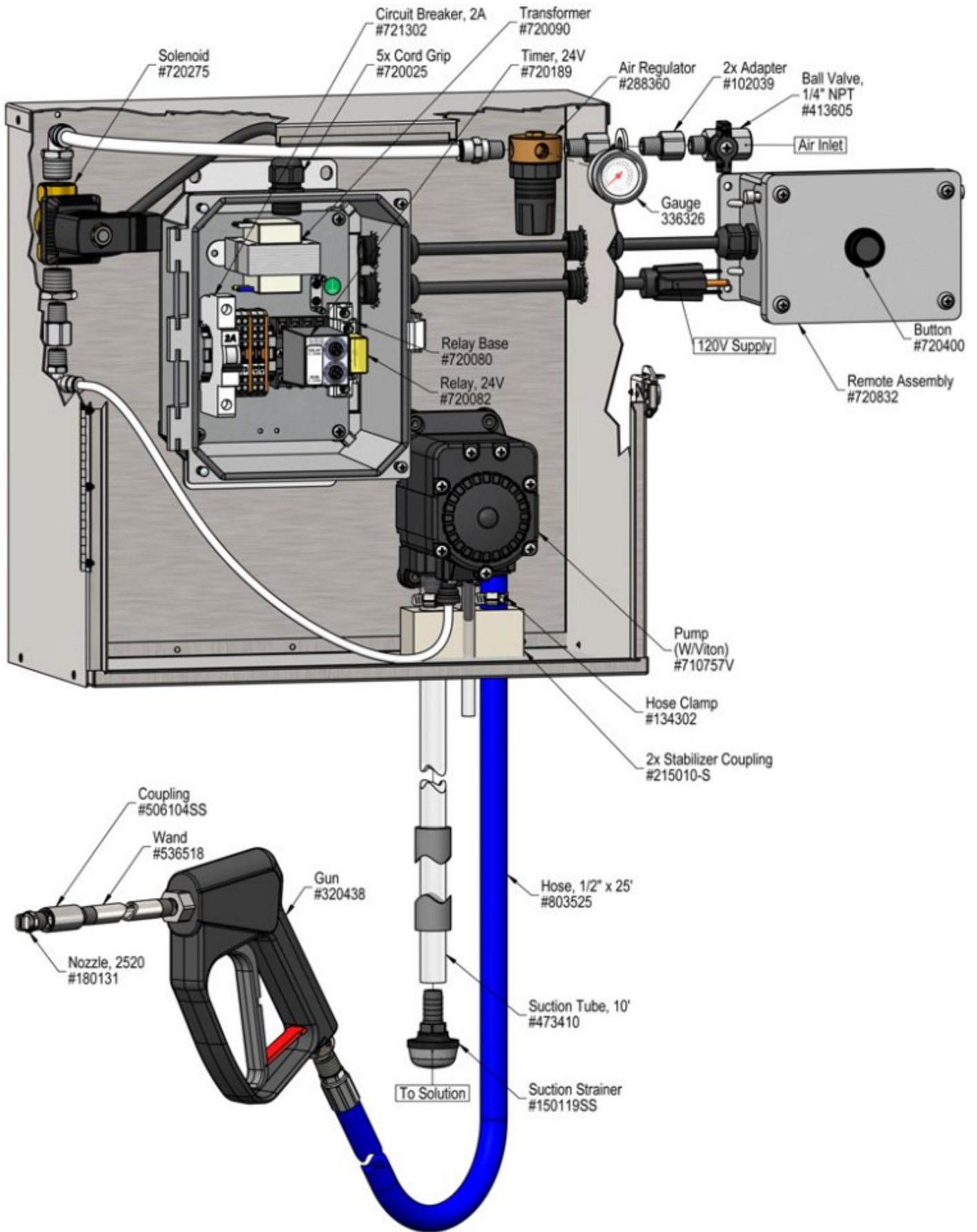

Troubleshooting Guide

Problem	Possible Cause / Solution	
	Startup	Maintenance
A) Air pump will not run or pump solution.	1,2,3	6,7,10,11
B) Will not draw chemical.	1,2,3	7,8,9
C) Pump runs too fast with no output.	2	8,9,10,11
D) Unit doesn't come on when switch is turned on.	4,5	
E) Unit comes on and runs continuously.	4	
F) Unit comes on but no solution through solenoid.	4	

Possible Cause / Solution	
Startup	Maintenance
<ol style="list-style-type: none"> 1. Inlet ball valve partially closed or air pressure too low. <ul style="list-style-type: none"> ◦ Completely open air inlet ball valve. ◦ The air regulator has been pre-set at 60 psi. Do not go over 100 PSI! 2. Chemical tube not immersed in container or container empty <ul style="list-style-type: none"> ◦ Immerse tube or replenish. 3. Hose kinked <ul style="list-style-type: none"> ◦ Straighten the hose. 4. Timer failed/Controller not set properly or malfunctioned <ul style="list-style-type: none"> ◦ Replace timer. See Controller manual. 5. May have electrical problems <ul style="list-style-type: none"> ◦ Have a qualified electrician check electrical connections. ◦ Ensure circuit breaker (5 amp) has not been tripped at control box. 	<ol style="list-style-type: none"> 6. Ice particles from condensation in air line — Air pump can periodically "freeze up" (stall) due to ice particles in the pump's exhaust (depending on air humidity & other factors) <ul style="list-style-type: none"> ◦ WAIT several seconds to allow the ice particles to melt and blow out, at which time the pump will automatically resume pumping. 7. Air regulator clogged or failed <ul style="list-style-type: none"> ◦ Clean or replace. 8. Chemical strainer clogged up <ul style="list-style-type: none"> ◦ Clean or replace. 9. Vacuum leak in suction line. <ul style="list-style-type: none"> ◦ Tighten the connection(s). 10. Chemical tube stretched out where tube attaches or pin hole/cut in tube sucking air. <ul style="list-style-type: none"> ◦ Cut off end of tube or replace tube. 11. Problem with air pump <ul style="list-style-type: none"> ◦ Refer to air pump instruction manual. ◦ https://www.xylem.com/en-us/brands/Flojet/flojet-products/g57-air-operated-double-diaphragm-pump ◦ Replace pump. 12. Use of an oiler in the airline will cause pump to stall <ul style="list-style-type: none"> ◦ Use only clean, dry air.

PREVENTIVE MAINTENANCE: When the unit will be out of service for extended periods, place chemical tube(s) in water and flush the chemical out of the unit to help prevent chemical from drying out and causing build-up. Periodically check and clean chemical strainer and replace if missing.

