

Lafferty Equipment Manufacturing, LLC Installation & Operation Instructions

Model # 933625-V · 2-Way FPV-PD/MM Concrete Foamer

REQUIREMENTS

Chemical Concentrate
Static Tank of Water

Compressed Air up to 6 CFM

Hose 3/4" ID x 50'

Nozzle 40150

OPTIONS

Stainless Steel Hose Racks

Large Stainless Steel Hose Rack # 224150

Stainless Steel Jug Racks Available

To Dilute and Dispense Ready-To-Use Acid Solution

414HC Acid Mixing Station # 980415

Drum & Tote Stick Lengths & Seal Materials

Drum Stick, 33" (Viton or EPDM) # 491643 / 491643-E

Drum Stick, 48" (Viton or EPDM) # 491648 / 491648-E

Drum Stick, 54" (Viton or EPDM) # 491645 / 491645-E

Tote Stick, 33" (Viton or EPDM) # 491653 / 491653-E

Tote Stick, 48" (Viton or EPDM) # 491654 / 491654-E

Tote Stick, 54" (Viton or EPDM) # 491656 / 491656-E

WEIGHT & DIMENSIONS

Single Package

Shipping Weight 38 lbs.

Shipping Dimensions 34" x 29" x 12"



Lafferty
EQUIPMENT MANUFACTURING LLC
CFS TECHNOLOGIES

www.laffertyequipment.com

501-851-2820

**WARNING! READ ALL
INSTRUCTIONS BEFORE
USING EQUIPMENT!**



OVERVIEW

The 2-Way FPV-PD/MM Concrete Foamer is a foam applicator for projecting 2- highly corrosive chemicals such as those used to remove concrete and for aluminum brightening. This acid-resistant system uses an air-operated, double-diaphragm, Flojet pump to draw a ready-to-use chemical solution from one static tank, or mix water and chemical concentrate from separate tanks. Compressed air is injected into the solution to greatly increase volume and coverage ability. Rich, clinging foam is projected through the hose, wand and fan nozzle on to any surface.

SAFETY & OPERATIONAL PRECAUTIONS

- For proper performance do NOT modify, substitute nozzle, hose diameter or length
- Manufacturer assumes no liability for the use or misuse of this unit.
- Wear protective clothing, gloves and eye-wear when working with chemicals.
- Always direct the discharge away from people and electrical devices.
- Follow the chemical manufacturer's safe handling instructions.
- DO NOT use chemicals that are not compatible with Viton diaphragms.

UNIT FLOW RATES

PSI	GPM
60	1.20

TO INSTALL (REFER TO DIAGRAM ON NEXT PAGE)

1. Mount the unit above solution supply level to prevent siphoning.
2. Place the strainer in the chemical solution(s).
3. Attach the discharge hose.
4. Attach a compressed airline to the air inlet ball valve. DO NOT TURN ON.
5. Air Filter/Dryer recommend.

How to Set Your Dilution Ratios:

This is a 2-Way Foamer, 1 chemical is straight or pre-diluted. The other is mixed on the fly.

1. For pre-diluted chemical: place the 1/2" tube in the solution
 2. For mixing on the fly: place one of the 1/4" tubes in a static tank of water and the other in chemical concentrate
 - NOTE: A second pre-diluted chemical can be used by placing both 1/4" tubes in pre-diluted chemical
- The internal adjustment knobs allow you to achieve wide range of dilution ratios.
 - Turn adjustment knobs counterclockwise to increase flow or clockwise to decrease flow.
 - For a starting place turn the water knob completely clockwise (closed) then turn 2 turns counterclockwise (open).
 - Then turn the chemical knob completely clockwise (closed) then counterclockwise (open) in 1/4 to 1/2 turn increments till required dilution ratios are achieved.
 - If ratios can't be achieved with the chemical knob all the way counterclockwise start turning water knob clockwise to shift more draw to the chemical side.

TO OPERATE

- **Always** make sure the discharge ball valve is closed or pointed in a safe direction before turning the air on. **Ball valve can be shut off at any time during operation but should not be left unattended for long periods of time. Expect a strong blast when re-opening ball valve.**
 - **The unit has been tested and is ready to operate, the air pressure preset at 60 PSI. This is the optimum pump pressure. Test "as is" before making any adjustments.**
 - The foam consistency knob is pre-set at 1/2 turn. To adjust foam consistency, turn the foam consistency needle valve counterclockwise a maximum of 1 turn for dryer foam and clockwise for wetter foam. Wait several seconds after each adjustment to see the results. Wet foam WILL remove concrete better than dry foam!
1. With the foam wand in hand direct the discharge in a safe direction **open the discharge ball valve and one of the blue chemical ball valves.**
 2. Open air ball valve, wait a few seconds for the pump to prime and start foaming.
 3. If the flow of foam surges, the foam consistency needle valve is open too much or the chemical concentration is too weak, reduce the air flow by turning the needle valve slowly clockwise until the foam flow stabilizes. Or add more chemical concentrate.
 4. A medium-wet foam will give the best cleaning results! Very dry foam will NOT clean as well!
 5. When foaming is complete:
 - Close the discharge ball valve.
 - Promptly return to the unit and close the air ball valve and the chemical ball valve. NEVER leave the air ball valve on when not in use.
 - Briefly re-open the discharge ball valve to relieve pressure in the hose.
 6. Rinse the work surface before the foam dries.

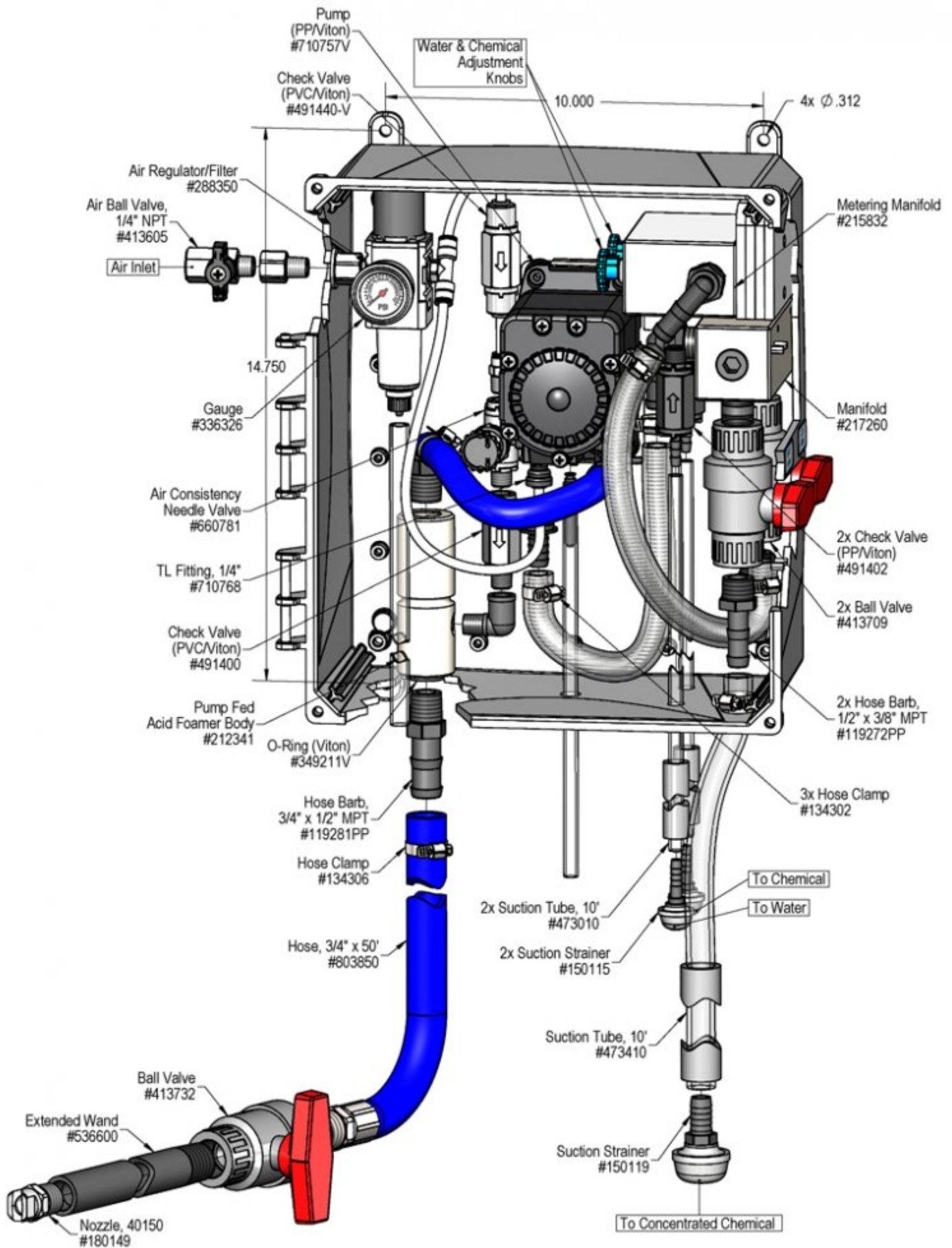

Troubleshooting Guide

Problem	Possible Cause / Solution	
	Startup	Maintenance
A) Air pump will not pump or runs with no output.	1, 2, 3, 4, 7	9, 10, 12, 13, 14
B) Foam surges and/or hose "bucks".	1, 2, 3, 4, 5, 6, 7	9, 12, 13
C) Foam output too wet.	1, 2, 3, 4, 5, 6	9, 12, 13
D) Foam output too dry.	2	
E) Cleaning results not acceptable.	5, 6, 8	

Possible Cause / Solution	
Startup	Maintenance
<ol style="list-style-type: none"> 1. Inlet ball valve partially closed or air pressure too low. <ul style="list-style-type: none"> ◦ Completely open air inlet ball valve. 2. Foam consistency needle valve open too much <ul style="list-style-type: none"> ◦ Adjust the needle valve slowly clockwise until foam stabilizes. Turn round handle slightly clockwise for wetter foam; open counterclockwise for dryer foam. Open a maximum of 1 turn. 3. Discharge ball valve not completely open or Discharge hose kinked <ul style="list-style-type: none"> ◦ Completely open the discharge ball valve / straighten hose 4. Solution tube not completely immersed in chemical or container empty <ul style="list-style-type: none"> ◦ Immerse tube or replenish chemical. 5. Dilution too weak <ul style="list-style-type: none"> ◦ Turn chemical needle valve counterclockwise or water needle valve clockwise for a stronger solution. ◦ Turn chemical needle valve clockwise or water needle valve counterclockwise for a weaker solution. 6. Improper chemical <ul style="list-style-type: none"> ◦ Ensure product is recommended for foaming and/or the application 7. Ice particles from condensation in air line — Air pump can periodically "freeze up" (stall) due to ice particles in the pump's exhaust (depending on air humidity & other factors) <ul style="list-style-type: none"> ◦ WAIT several seconds to allow the ice particles to melt and blow out, at which time the pump will automatically resume pumping. 8. Soil has hardened on surface <ul style="list-style-type: none"> ◦ Always rinse foam before it dries. 	<ol style="list-style-type: none"> 9. Solution strainer blocked <ul style="list-style-type: none"> ◦ Clean or replace 10. Air regulator failed <ul style="list-style-type: none"> ◦ Clean or replace 11. Air or water check valve(s) failed <ul style="list-style-type: none"> ◦ Clean or replace 12. Discharge hose wrong size or kinked (See REQUIREMENTS, page 1). <ul style="list-style-type: none"> ◦ Straighten the hose 13. Nozzle size too small or missing <ul style="list-style-type: none"> ◦ See REQUIREMENTS, page 1. 14. Problem with air pump <ul style="list-style-type: none"> ◦ Refer to air pump instruction manual. ◦ https://www.xylem.com/en-us/brands/Flojet/flojet-products/g57-air-operated-double-diaphragm-pump ◦ Replace pump.

PREVENTIVE MAINTENANCE: When the unit will be out of service for extended periods, place chemical tube(s) in water and flush the chemical out of the unit to help prevent chemical from drying out and causing build-up. Periodically check and clean chemical strainer and replace if missing.

