

Lafferty Equipment Manufacturing, Inc. Installation & Operation Instructions

Model # 941387 · Portable 20 Gallon Liberty LC Foamer

REQUIREMENTS

Chemical Concentrate
Water to Fill Tank

Compressed Air up to 6 CFM

Hose 3/4" ID x 40'

Nozzle 50250

OPTIONS

Drain Foamer Attachment

Drain Foamer Attachment (Freedom,
2.5 & Liberty) # 538245

Alternate Check Valve - EPDM Standard

Check Valve, Chemical, PP/Viton, 1/4" # 491315

WEIGHT & DIMENSIONS

Single Package

Shipping Weight 82 lbs.

Shipping Dimensions 48" x 26" x 24"



Lafferty
EQUIPMENT MANUFACTURING INC.

www.laffertyequipment.com

501-851-2820

**WARNING! READ ALL
INSTRUCTIONS BEFORE
USING EQUIPMENT!**



OVERVIEW

The Portable 20 Gallon Liberty LC Foamer is a medium volume venturi foam applicator designed for facilities with low or fluctuating water pressure. It projects foaming chemicals on to any surface up close or at distances up to 10 feet. This unit features an all stainless steel 4-wheel cart and enclosure and uses a cost-effective Flojet air-operated, double-diaphragm pump to draw water from the 20 gallon tank and provide the pressure for the venturi "LC Foamer". The LC Foamer body draws and blends chemical concentrate into the water stream to create an accurately diluted solution. Compressed air is injected into the solution to greatly increase volume and coverage ability and rich, clinging foam is projected through the hose, wand, and fan nozzle.

SAFETY & OPERATIONAL PRECAUTIONS

- For proper performance do NOT modify, substitute nozzle, hose diameter or length
- Manufacturer assumes no liability for the use or misuse of this unit.
- Wear protective clothing, gloves and eye-wear when working with chemicals.
- Always direct the discharge away from people and electrical devices.
- Follow the chemical manufacturer's safe handling instructions.
- DO NOT use d-Limonene or other chemicals that are not compatible with the Santoprene diaphragms.
- Viton upgrade is available.

TO INSTALL (REFER TO DIAGRAM ON NEXT PAGE)

1. Remove the lid and fill the tank with water to the desired level. Replace lid.
2. Place a container of chemical concentrate in the jug rack.
3. Once you are in the area to be foamed, attach a compressed airline to the inlet ball valve. DO NOT TURN ON

Set the chemical dilution ratio by threading one of the color coded metering tips into each chemical check valve. See chemical labels for dilution ratio recommendation or consult your chemical supplier.

- For the strongest dilution ratio do NOT install a colored metering tip.
- The dilution ratios in the metering tip chart are based on water thin chemicals with a viscosity of 1CPS.
- Thicker chemicals will require a larger tip than the ratios shown in the chart.
- Application results will ultimately determine final tip color.
- Select the tip color that is closest to your desired chemical strength and thread it into the tip holder. **DO NOT OVER-TIGHTEN.**
- Push the chemical tube over the check valve barb and place the suction tube in the chemical concentrate.
- If necessary, cut suction tube(s) to length before attaching suction strainer.

TO OPERATE

- **Always make sure the discharge ball valve is closed or pointed in a safe direction before turning the air on. Ball valve can be shut off at any time during operation but should not be left unattended for long periods of time. Expect a strong blast when re-opening ball valve.**
 - The unit has been tested and is ready to operate. The pump air pressure regulator is preset and locked at 90 PSI. This is the optimum pump pressure. Test "as is" before making any foam consistency adjustments.
1. Final dilution ratios and air adjustments will now have to be made.
 2. The foam consistency knob is pre-set. IF adjustments are needed turn the foam consistency needle valve counterclockwise for drier foam and clockwise for wetter foam. Make only small turns and wait several seconds after each adjustment to see the results.
 - Too much foam consistency air can cause: the pump to stall; the hose to buck and jump; poor foam; the venturi to fail.
 - Medium-wet foam will give the best results! Dry foam will NOT clean as well!
 3. With wand in hand direct the discharge in a safe direction, open the discharge ball valve.
 4. Open the air ball valve.
 5. Wait several seconds for pump to prime and the foamer to draw the chemical.
 6. You may have to try different sized metering tips and air settings until foam consistency and cleaning results are acceptable. Once this is set you are ready to start application.
 7. When foaming is complete, close the discharge ball valve. Return to the unit and close the air ball valve. Briefly re-open the discharge ball valve to relieve pressure in the hose.
 8. Rinse the work surface before the foam dries.

METERING TIP SELECTION

METERING TIP COLOR	OZ/MIN	DILUTION RATIO @ 80 PSI
Brown	0.56	434:1
Clear	0.88	276:1
Bright Purple	1.38	176:1
White	2.15	113:1
Pink	2.93	83:1
Corn Yellow	3.84	63:1
Dark Green	4.88	50:1
Orange	5.77	42:1
Gray	6.01	40:1
Light Green	7.01	35:1
Med. Green	8.06	30:1
Clear Pink	9.43	26:1
Yellow Green	11.50	21:1
Burgundy	11.93	20:1
Pale Pink	13.87	18:1
Light Blue	15.14	16:1
Dark Purple	17.88	14:1
Navy Blue	25.36	10:1
Clear Aqua	28.60	9:1
Black	50.00	—
No Tip Ratio Up To:		6:1

The dilution ratios above are approximate values. Due to chemical viscosity, actual dilution ratios may vary.

FORMULA

GPM × 128 ÷ Desired Dilution Ratio = oz/min

- See Unit Flow Rates chart for GPM
- Use 20 for 20:1 dilution ratio, 30 for 30:1, etc.
- Match calculated ounces per minute (oz/min) to nearest oz/min in Metering Tip Selection chart.

UNIT FLOW RATES

PSI	GPM
80	1.90

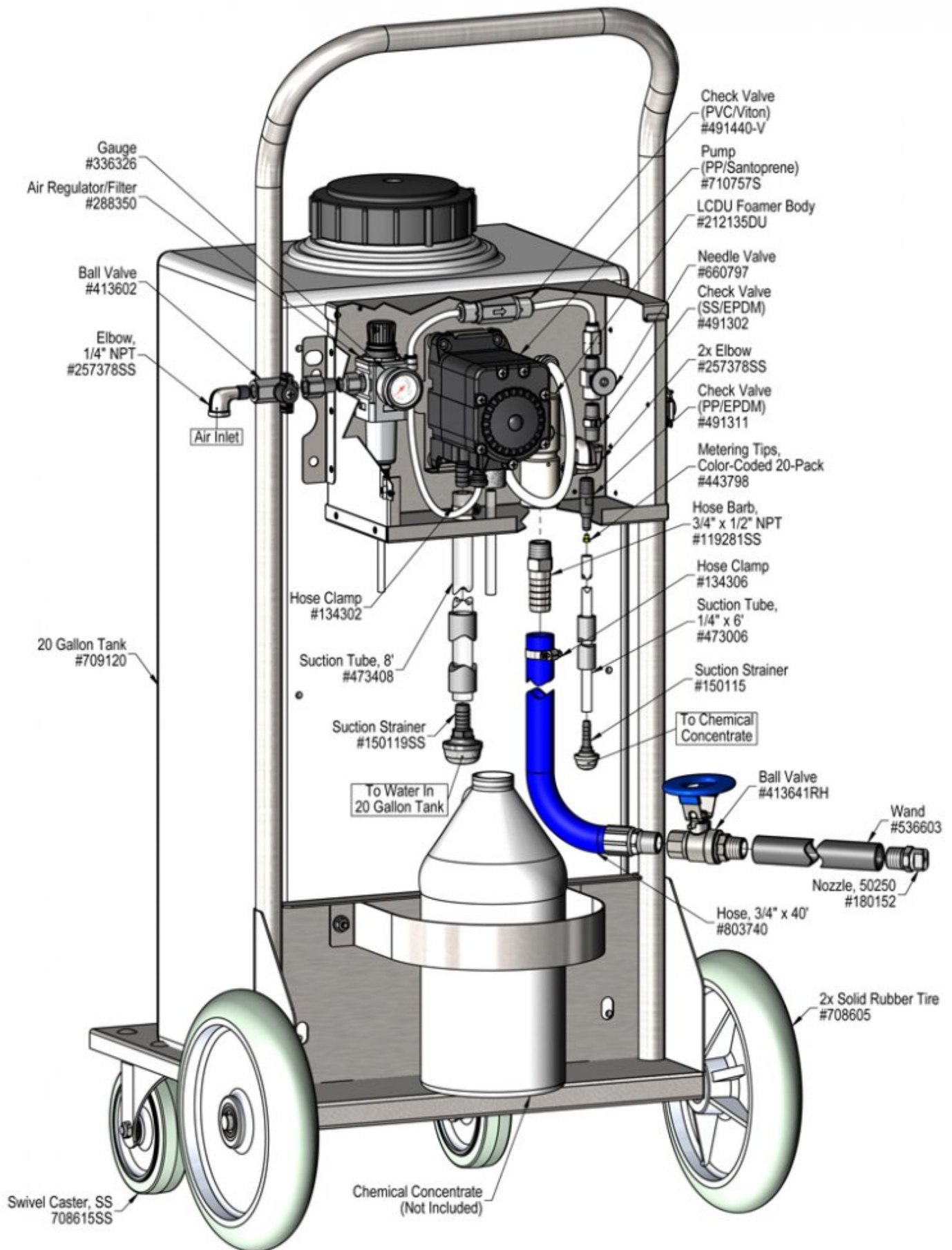

Troubleshooting Guide

Problem	Possible Cause / Solution	
	Startup	Maintenance
A) Air pump will not prime or runs with no output.	1, 2, 3, 4, 5	9, 10, 12, 13, 14
B) Will not draw chemical.	1, 2, 3, 4, 5	9, 12, 13
C) Foam surges and / or hose "bucks".	1, 2, 4, 5, 6, 7	9, 10, 11, 12
D) Foam output too wet.	1, 2, 4, 5, 6, 7	9, 12, 13
E) Foam output too dry.	2	
F) Cleaning results not acceptable.	6, 7, 8	

Possible Cause / Solution	
Startup	Maintenance
<ol style="list-style-type: none"> 1. Inlet ball valve partially closed or air pressure too low. <ul style="list-style-type: none"> ◦ Make sure air pressure is set at 90 PSI. 2. Foam consistency needle valve open too much <ul style="list-style-type: none"> ◦ Adjust the needle valve slowly clockwise till foam stabilizes. ◦ Turn round handle slightly clockwise for wetter foam; open counterclockwise for dryer foam. ◦ Open a maximum of 1/2 turn or the foamer will not draw chemical. 3. Pump requires manual priming on initial startup or has run dry. (Priming may take up to 30 seconds.) <ul style="list-style-type: none"> ◦ Remove the clear water suction tube and fill the tube with water and reconnect. The pump should readily prime. Once the pump's internal valves are wet, the pump will prime by itself. 4. Discharge ball valve not completely open or discharge hose kinked <ul style="list-style-type: none"> ◦ Completely open the discharge ball valve / straighten hose. 5. Water or chemical tubes not completely immersed or container(s) empty <ul style="list-style-type: none"> ◦ Immerse tubes or replenish. ◦ If pump has run dry, re-prime the pump. (See #3, above.) 6. Dilution too weak <ul style="list-style-type: none"> ◦ Install a larger metering tip (chemical viscosity is thicker than water). 7. Improper chemical <ul style="list-style-type: none"> ◦ Ensure product is recommended for foaming and/or the application. 8. Soil has hardened on surface <ul style="list-style-type: none"> ◦ Always rinse foam before it dries 	<ol style="list-style-type: none"> 9. Water or chemical strainers blocked <ul style="list-style-type: none"> ◦ Clean or replace. 10. Air regulator failed <ul style="list-style-type: none"> ◦ Clean or replace. 11. Discharge hose kinked <ul style="list-style-type: none"> ◦ Straighten the hose. 12. Nozzle size too small or missing <ul style="list-style-type: none"> ◦ Use only nozzles specified. (See Requirements, page 1.) 13. Problem with air pump <ul style="list-style-type: none"> ◦ Refer to air pump instruction manual/CD. ◦ If spool stopped in neutral position, press the RESET button

PREVENTIVE MAINTENANCE: When the unit will be out of service for extended periods, place chemical tube(s) in water and flush the chemical out of the unit to help prevent chemical from drying out and causing build-up. Periodically check and clean chemical strainer and replace if missing.

