

# Lafferty Equipment Manufacturing, LLC Installation & Operation Instructions

Model # 969753 · Model 20 SS Bypass 3-Way Airless Foam/Spray System (NO HOSE)

## REQUIREMENTS

|                   |                                      |
|-------------------|--------------------------------------|
| Water Temperature | up to 180°F                          |
| Pressure Washer   | 3.5 - 5.5 GPM                        |
| Discharge Hose    | 3/8" ID minimum<br>Up to 200' length |

## OPTIONS

|   |            |
|---|------------|
| <b>Stainless Steel Hose Racks</b>             |            |
| Large Stainless Steel Hose Rack               | # 224150   |
| <b>Stainless Steel Jug Racks Available</b>    |            |
| <b>Safe Flow Lid™ for 1 Gallon Jugs</b>       |            |
| Lid, Suction Tube, and Strainer               | # 709101   |
| <b>Pressure Washer Hose &amp; Trigger Gun</b> |            |
| HP 3/8" x 50' Hose & Trigger Gun Kit          | # 807069   |
| <b>Inlet Jumper Hose</b>                      |            |
| Hose, 3/8" x 6', High Pressure                | # 195006   |
| Hose, 3/8" x 15', SS, BNM, High Pressure      | # 195015SS |

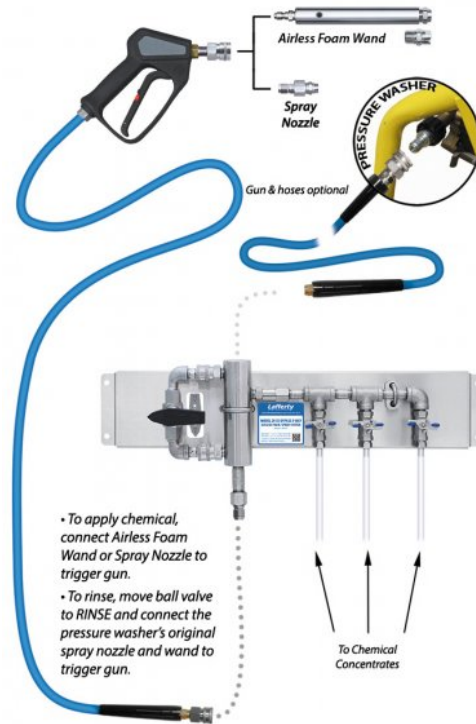

**Lafferty**  
EQUIPMENT MANUFACTURING LLC

 **CFS** TECHNOLOGIES

[www.laffertyequipment.com](http://www.laffertyequipment.com)

501-851-2820

**WARNING! READ ALL  
INSTRUCTIONS BEFORE  
USING EQUIPMENT!**



## OVERVIEW

Designed for 3.5–5.5 GPM pressure washers. The Model 20 SS Bypass 3-Way Airless Foam/Spray System is a wash/rinse system for quickly diluting and applying three chemicals and rinsing through the same hose. This venturi unit draws and blends three separate chemicals or three different concentrations of the same chemical into the water stream to create an accurately diluted solution. The solution then flows through the hose and gun to the airless foam wand which draws in atmospheric air to create and project wet, clinging foam on to surfaces up close or at distances up to 25 feet with interchangeable fan and zero degree nozzles. Quick connect the fan pattern sprayer nozzle to apply non-foaming chemicals. Open the bypass ball valve to rinse at full volume and pressure.

### SAFETY & OPERATIONAL PRECAUTIONS

- For proper performance do NOT modify, substitute nozzle, hose diameter or length.
- Manufacturer assumes no liability for the use or misuse of this unit.
- Wear protective clothing, gloves and eye wear when working with chemicals.
- Always direct the discharge away from people and electrical devices.
- Follow the chemical manufacturer's safe handling instructions.

### TO INSTALL (REFER TO DIAGRAM ON NEXT PAGE)

If you are connecting to a potable water supply follow all local codes for backflow prevention.

1. Mount the unit to a suitable surface above the chemical supply to prevent siphoning.
2. Connect hose(s) as shown in the diagram.
3. Flush any new plumbing of debris before connecting water.
4. Connect water supply. Install a water filter if water piping is older or has known contaminants.

Set the chemical dilution ratio by threading one of the color coded metering tips into each chemical check valve. See chemical labels for dilution ratio recommendation or consult your chemical supplier.

- For the strongest dilution ratio do NOT install a colored metering tip.
- The dilution ratios in the metering tip chart are based on water thin chemicals with a viscosity of 1CPS.
- Thicker chemicals will require a larger tip than the ratios shown in the chart.
- Application results will ultimately determine final tip color.
- Select the tip color that is closest to your desired chemical strength and thread it into the tip holder. **DO NOT OVER-TIGHTEN.**
- Push the chemical tube over the check valve barb and place the suction tube in the chemical concentrate.
- If necessary, cut suction tube(s) to length before attaching suction strainer.

### TO OPERATE

#### TO FOAM OR SPRAY

1. Remove the rinse nozzle and quick connect the foam wand or the spray nozzle to your trigger gun as shown in the diagram. If your trigger gun doesn't have quick disconnects you will have to install them.
2. Turn the by-pass ball valve to the "foam" position.
3. Open 1-chemical ball valve.
4. Hold the trigger gun firmly and direct the discharge in a safe direction. Pull the trigger and begin application.
5. Make final metering tip adjustments based on application results. Try the next larger sized metering tip until the results are acceptable.
6. Repeat step 3 for additional chemicals

#### TO RINSE

1. When foaming/spraying is completed, release the trigger.
2. Replace the airless foam wand or low pressure spray nozzle with the original pressure washer rinse nozzle or the included rinse nozzle (provided with select models).
3. Close the chemical ball valves, and open the by-pass ball valve.
4. Rinse the work surface as you normally would and rinse before the chemical dries.
5. If the unit will not be used for a period of time it is BEST to draw fresh water through the pick up tube(s) to prevent chemical from drying inside the components.

### METERING TIP SELECTION

| METERING TIP COLOR  | DILUTION RATIO AT GPM |       |        |        |        |
|---------------------|-----------------------|-------|--------|--------|--------|
|                     | 3.5                   | 4.0   | 4.5    | 5.0    | 5.5    |
| Brown               | 800:1                 | 914:1 | 1029:1 | 1143:1 | 1257:1 |
| Clear               | 509:1                 | 582:1 | 655:1  | 727:1  | 800:1  |
| Bright Purple       | 325:1                 | 371:1 | 417:1  | 464:1  | 510:1  |
| White               | 208:1                 | 238:1 | 268:1  | 298:1  | 327:1  |
| Pink                | 153:1                 | 175:1 | 197:1  | 218:1  | 240:1  |
| Corn Yellow         | 117:1                 | 133:1 | 150:1  | 167:1  | 183:1  |
| Dark Green          | 92:1                  | 105:1 | 118:1  | 131:1  | 144:1  |
| Orange              | 78:1                  | 89:1  | 100:1  | 111:1  | 122:1  |
| Gray                | 75:1                  | 85:1  | 96:1   | 106:1  | 117:1  |
| Light Green         | 64:1                  | 73:1  | 82:1   | 91:1   | 100:1  |
| Med. Green          | 56:1                  | 64:1  | 71:1   | 79:1   | 87:1   |
| Clear Pink          | 48:1                  | 54:1  | 61:1   | 68:1   | 75:1   |
| Yellow Green        | 39:1                  | 45:1  | 50:1   | 56:1   | 61:1   |
| Burgundy            | 38:1                  | 43:1  | 48:1   | 54:1   | 59:1   |
| Pale Pink           | 32:1                  | 37:1  | 42:1   | 46:1   | 51:1   |
| Light Blue          | 30:1                  | 34:1  | 38:1   | 42:1   | 46:1   |
| Dark Purple         | 25:1                  | 29:1  | 32:1   | 36:1   | 39:1   |
| Navy Blue           | 18:1                  | 20:1  | 23:1   | 25:1   | 28:1   |
| Clear Aqua          | 16:1                  | 18:1  | 20:1   | 22:1   | 25:1   |
| Black               | 9:1                   | 10:1  | 12:1   | 13:1   | 14:1   |
| No Tip Ratio Up To: | 6:1                   | 7:1   | 8:1    | 9:1    | 10:1   |

*The dilution ratios above are approximate values. Due to chemical viscosity, actual dilution ratios may vary.*

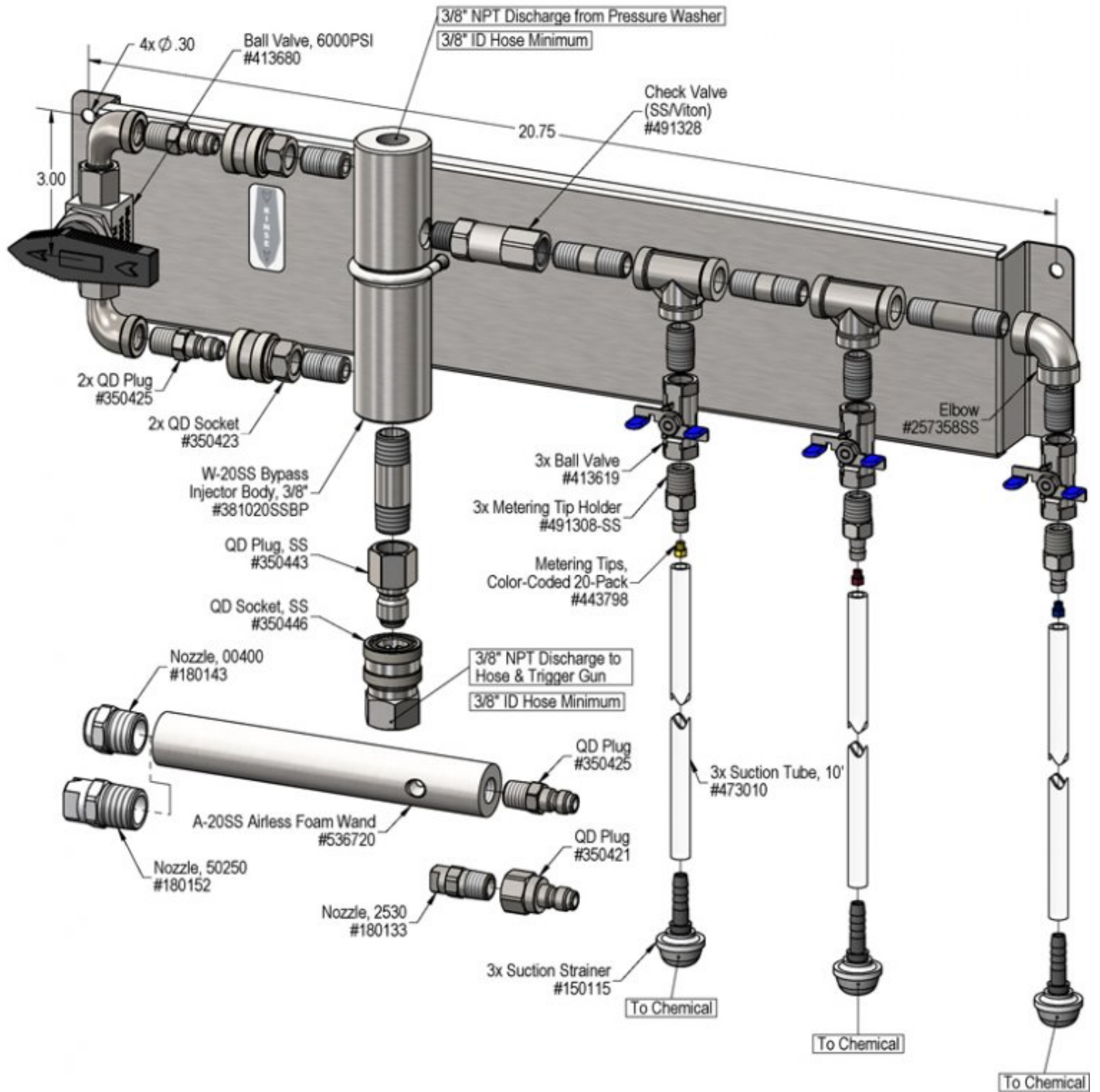

## Troubleshooting Guide

| Problem                         | Possible Cause / Solution |                      |
|---------------------------------|---------------------------|----------------------|
|                                 | Startup                   | Maintenance          |
| A) Unit will not draw chemical. | 1, 2, 3, 7                | 8, 9, 10, 11, 12, 13 |
| B) Does not foam properly       | 1, 4, 5, 7                | 8, 9, 11, 12         |
| C) Using too much chemical      | 6                         |                      |

| Possible Cause / Solution  |  |
|--|--|
| Startup  | Maintenance  |
| <ol style="list-style-type: none"> <li><b>1. Water volume too low</b> <ul style="list-style-type: none"> <li>◦ See requirements.</li> </ul> </li> <li><b>2. Water inlet clogged</b> <ul style="list-style-type: none"> <li>◦ Clean the water inlet. DO NOT DRILL OUT</li> </ul> </li> <li><b>3. Hose size too small</b> <ul style="list-style-type: none"> <li>◦ MUST be 3/8" ID hose, minimum</li> </ul> </li> <li><b>4. Ensure chemical is recommended for foaming and/or the application</b> <ul style="list-style-type: none"> <li>◦ Refer to chemical manufacturer.</li> </ul> </li> <li><b>5. Dilution too weak / Chemical is very thick.</b> <ul style="list-style-type: none"> <li>◦ Install larger metering tip or remove metering tip.</li> </ul> </li> <li><b>6. Dilution too strong / No metering tip installed or wrong metering tip installed</b> <ul style="list-style-type: none"> <li>◦ Install a metering tip or install a smaller metering tip</li> <li>◦ If the exact dilution ratio cannot be achieved with metering tips, pre-dilute the chemical with water before drawing it into the injector for final dilution and application</li> </ul> </li> <li><b>7. Hose too long</b> <ul style="list-style-type: none"> <li>◦ Use a shorter discharge hose to alleviate back pressure on the injector</li> <li>◦ The allowable length of hose varies based on individual pressure washers and equipment setups. 200' max recommended hose length between injector and nozzle. Longer hose could affect dilution ratios.</li> </ul> </li> </ol> | <ol style="list-style-type: none"> <li><b>8. Chemical check valve stuck, clogged, loose or failed</b> <ul style="list-style-type: none"> <li>◦ Clean, tighten or rebuild.</li> </ul> </li> <li><b>9. Chemical strainer or metering tip blocked</b> <ul style="list-style-type: none"> <li>◦ Clean or replace chemical strainer and/or metering tip.</li> </ul> </li> <li><b>10. Chemical tube stretched out where tube slides over check valve or pin hole/cut in chemical tube (sucking air in) which reduces chemical intake. Chemical tube not immersed in chemical or depleted.</b> <ul style="list-style-type: none"> <li>◦ Cut off end of tube, replace tube or immerse tube in chemical</li> </ul> </li> <li><b>11. Discharge nozzle is wrong size</b> <ul style="list-style-type: none"> <li>◦ Install correct nozzle (see parts drawing)</li> <li>◦ Use only provided nozzles/wands for chemical application</li> </ul> </li> <li><b>12. Chemical build-up or hard water scale may have formed in the foam wand or injector body causing poor or no chemical pick-up</b> <ul style="list-style-type: none"> <li>◦ Follow Preventive Maintenance instructions below, using hot water and/or descaling acid. When there is no draw at all, carefully remove inlet fitting and chemical check valve. Soak injector body and or foam wand in de-scaling acid.</li> </ul> </li> <li><b>13. Bypass ball valve open (Bypass models only)</b> <ul style="list-style-type: none"> <li>◦ Close bypass valve.</li> </ul> </li> </ol> |

**PREVENTIVE MAINTENANCE:** When the unit will be out of service for extended periods, place chemical tube(s) in water and flush the chemical out of the unit to help prevent chemical from drying out and causing build-up. Periodically check and clean chemical strainer and replace if missing.

