

Lafferty Equipment Manufacturing, LLC Installation & Operation Instructions

Model # 918058 · 2-Way W-20SS Spray-All

REQUIREMENTS

Chemical Concentrate

| | |
|---------------|--------------------|
| Water | |
| Temperature | up to 180°F |
| Pressure | 400 to 1000 PSI |
| Flow | 3.11 GPM @ 700 PSI |
| Supply Line | 3/8" |
| Hose | |
| Hose | 3/8" ID x 50' |
| Nozzle | |
| Nozzle | 2520 |

OPTIONS

Stainless Steel Hose Racks

Large Stainless Steel Hose Rack # 224150

Stainless Steel Jug Racks

Jug Rack, SS, 1 Gallon, Round/Square # 224200

Jug Rack, SS, 2 1/2 Gallon # 224210

Jug Rack, SS, 5 Gallon, Round/Square # 224215

Safe Flow Lid™ for 1 Gallon Jugs

Lid, Suction Tube, and Strainer # 709101

Alternate Check Valve - EPDM Standard

Check Valve, Chemical, SS, Viton, 1/4" # 491324-V



(Trigger gun and wand are not shown to scale with unit.)

Lafferty
EQUIPMENT MANUFACTURING LLC
CFS TECHNOLOGIES

www.laffertyequipment.com

501-851-2820

**WARNING! READ ALL
INSTRUCTIONS BEFORE
USING EQUIPMENT!**



OVERVIEW

The 2-Way W-20SS Spray-All is a water-driven spray applicator for applying up to 2 chemical solutions on to a variety of surfaces at 3.11 GPM @ 700 PSI. This stainless steel venturi injection system uses high water pressure (400 - 1000 PSI) to draw and blend chemical concentrate into the water stream using precision metering tips. The accurately diluted solution is then projected through the discharge hose, trigger gun, wand and fan nozzle. Use the ball valves to inject the 2 chemicals separately or simultaneously.

SAFETY & OPERATIONAL PRECAUTIONS

- For proper performance do NOT modify, substitute nozzle, hose diameter or length.
- Manufacturer assumes no liability for the use or misuse of this unit.
- Wear protective clothing, gloves and eye wear when working with chemicals.
- Always direct the discharge away from people and electrical devices.
- Follow the chemical manufacturer's safe handling instructions.

TO INSTALL (REFER TO DIAGRAM ON NEXT PAGE)

1. Mount the unit to a suitable surface above the chemical supply to prevent siphoning.
2. Connect the discharge hose as shown in the diagram.
3. To prevent blocking the small water jets in the injector flush any new plumbing of debris before connecting water.
4. Connect water supply. If water piping is older or has known contaminants install a water filter.

Set the chemical dilution ratio by threading one of the color coded metering tips into each chemical check valve. See chemical labels for dilution ratio recommendation or consult your chemical supplier.

- For the strongest dilution ratio do NOT install a colored metering tip.
- The dilution ratios in the metering tip chart are based on water thin chemicals with a viscosity of 1CPS.
- Thicker chemicals will require a larger tip than the ratios shown in the chart.
- Application results will ultimately determine final tip color.
- Select the tip color that is closest to your desired chemical strength and thread it into the tip holder. **DO NOT OVER-TIGHTEN.**
- Push the chemical tube over the check valve barb and place the suction tube in the chemical concentrate.
- If necessary, cut suction tube(s) to length before attaching suction strainer.

TO OPERATE

1. Make final metering tip adjustments based on application results.
2. With trigger gun in hand open the inlet ball valve and 1 chemical ball valve.
3. Pull the trigger and begin application.
4. When application is completed, release the trigger then close the inlet ball valve and the chemical ball valve.
5. Briefly squeeze the trigger to relieve pressure in hose.

METERING TIP SELECTION

| METERING TIP COLOR | OZ/MIN | DILUTION RATIO @ 700 PSI |
|---------------------|--------|--------------------------|
| Brown | 0.56 | 711:1 |
| Clear | 0.88 | 452:1 |
| Bright Purple | 1.38 | 288:1 |
| White | 2.15 | 185:1 |
| Pink | 2.93 | 136:1 |
| Corn Yellow | 3.84 | 104:1 |
| Dark Green | 4.88 | 82:1 |
| Orange | 5.77 | 69:1 |
| Gray | 6.01 | 66:1 |
| Light Green | 7.01 | 57:1 |
| Med. Green | 8.06 | 49:1 |
| Clear Pink | 9.43 | 42:1 |
| Yellow Green | 11.50 | 35:1 |
| Burgundy | 11.93 | 33:1 |
| Pale Pink | 13.87 | 29:1 |
| Light Blue | 15.14 | 26:1 |
| Dark Purple | 17.88 | 22:1 |
| Navy Blue | 25.36 | 16:1 |
| Clear Aqua | 28.60 | 14:1 |
| Black | 50.00 | 8:1 |
| No Tip Ratio Up To: | | 7:1 |

The dilution ratios above are approximate values. Due to chemical viscosity, actual dilution ratios may vary.

FORMULA

GPM × 128 ÷ Desired Dilution Ratio = oz/min

- See Unit Flow Rates chart for GPM
- Use 20 for 20:1 dilution ratio, 30 for 30:1, etc.
- Match calculated ounces per minute (oz/min) to nearest oz/min in Metering Tip Selection chart.

UNIT FLOW RATES

| PSI | GPM |
|------|------|
| 400 | 2.35 |
| 500 | 2.63 |
| 600 | 2.88 |
| 700 | 3.11 |
| 800 | 3.32 |
| 900 | 3.53 |
| 1000 | 3.72 |

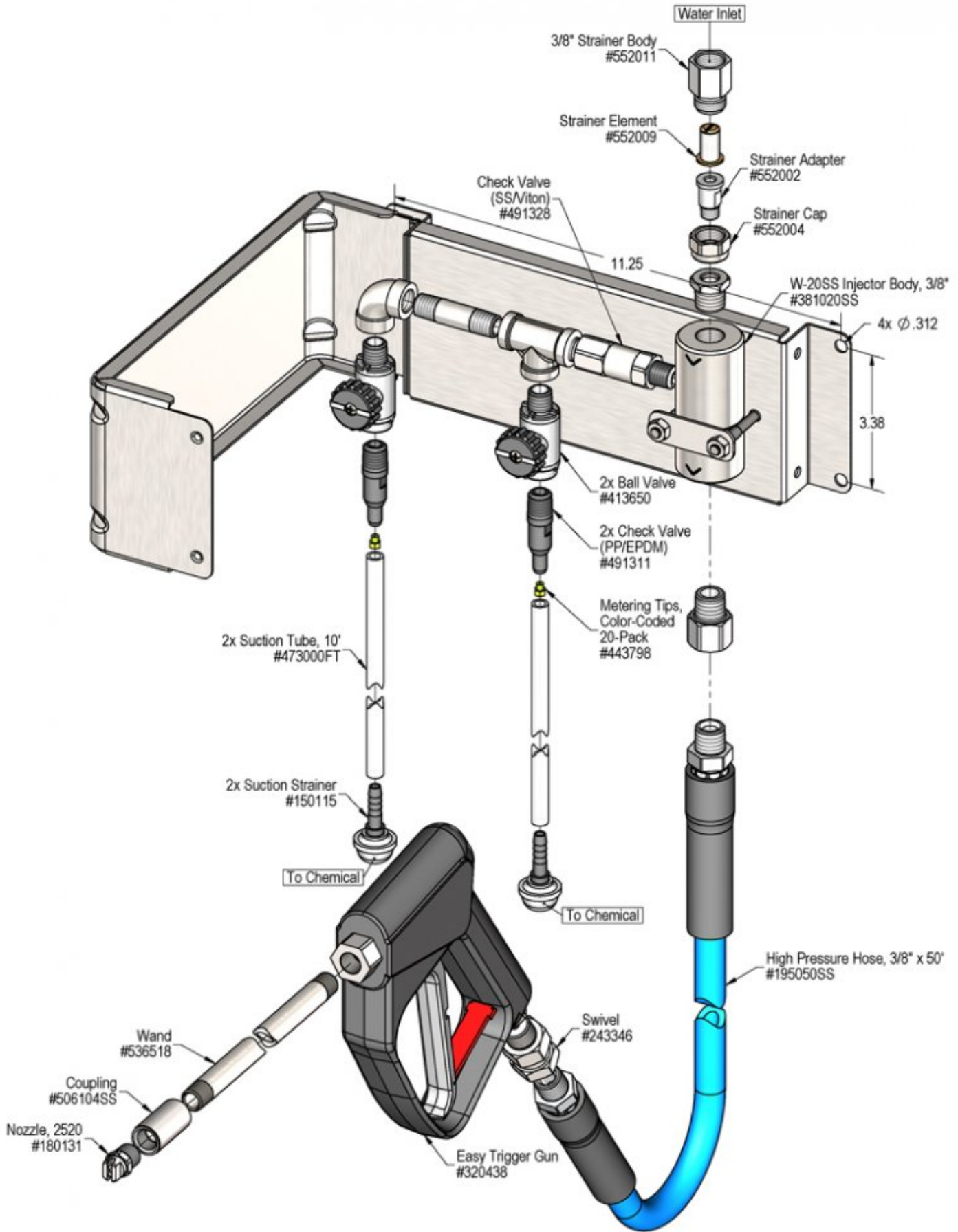

Troubleshooting Guide

| Problem | Possible Cause / Solution | |
|---|---------------------------|--------------------------|
| | Startup | Maintenance |
| A) Unit will not draw chemical | 1, 4, 5, 6, 7 | 8, 9, 10, 11, 12, 13, 14 |
| B) Dilution too weak | 2, 4, 5 | 8, 9, 10, 11, 12, 13, 14 |
| C) Dilution too strong | 3 | 14 |
| D) Water backing up into chemical container | | 8 |

| Possible Cause / Solution | |
|---|--|
| Startup | Maintenance |
| <ol style="list-style-type: none"> 1. Inlet ball valve or trigger gun not completely open ◦ Completely open the inlet ball valve. 2. Not enough chemical - metering tip too small ◦ Install larger metering tip. 3. No metering tip installed or metering tip too large ◦ Install smaller metering tip. 4. Chemical tube not immersed in chemical or chemical depleted ◦ Immerse tube or replenish. 5. Discharge hose too long for available water pressure, kinked or wrong size ◦ Straighten the hose or replace hose. 6. Nozzle size too small (SEE REQUIREMENTS) 7. Water pressure or water volume too low/inlet piping too small causing poor chemical pick up ◦ Increase water pressure or water volume | <ol style="list-style-type: none"> 8. Chemical check valve stuck or failed ◦ Clean or replace. 9. Chemical strainer or metering tip partially blocked ◦ Clean or replace chemical strainer and/or metering tip. 10. Chemical tube stretched out or pin hole/cut in chemical tube ◦ Cut off end of tube or replace tube. 11. Vacuum leak in chemical pick-up connections ◦ Tighten the connection. 12. Water strainer clogged or missing/injector inlet orifice clogged ◦ Clean or replace strainer; check/clean inlet orifice for obstructions. DO NOT DRILL OUT. 13. Hard water scale or chemical build-up may have formed in the injector body causing poor or no chemical pick-up ◦ Follow Preventive Maintenance instructions below, using hot water and/or de-scaling acid. When there is no draw at all, carefully remove fittings and soak entire injector body in de-scaling acid. 14. More than one chemical ball valve is open ◦ 2-Way and 3-Way models only |

PREVENTIVE MAINTENANCE: When the unit will be out of service for extended periods, place chemical tube(s) in water and flush the chemical out of the unit to help prevent chemical from drying out and causing build-up. Periodically check and clean chemical strainer and replace if missing.

