

Lafferty Equipment Manufacturing, LLC Installation & Operation Instructions

Model # VC-1083 · Model 20 SS Hose End Airless Foamer With Trigger Gun

REQUIREMENTS

Water Temperature	up to 180°F
Pressure Washer	2.2 - 5.5 GPM
Supply Hose	3/8" ID minimum

OPTIONS

Stainless Steel Hose Racks	
Large Stainless Steel Hose Rack	# 224150
Unit Storage Rack	
Compact Foamer/Sprayer Rack, Stainless Steel	# 224301
Safe Flow Lid™ for 1 Gallon Jugs	
Lid, Suction Tube, and Strainer	# 709101



Lafferty
EQUIPMENT MANUFACTURING LLC
CFS TECHNOLOGIES

www.laffertyequipment.com
501-851-2820

**WARNING! READ ALL
INSTRUCTIONS BEFORE
USING EQUIPMENT!**



OVERVIEW

Designed for 2.2–5.5 GPM pressure washers. The Model 20 Stainless Steel Hose End Airless Foamer is an airless foam applicator for quickly diluting and applying foaming chemicals. This venturi unit draws and blends chemical concentrate into the water stream to create an accurately diluted solution. The solution then flows through the airless foam wand which draws in atmospheric air to create and project wet, clinging foam on to surfaces up close or at distances up to 25 feet with interchangeable fan and zero degree nozzles.

SAFETY & OPERATIONAL PRECAUTIONS

- For proper performance do NOT modify, substitute nozzle, hose diameter or length.
- Manufacturer assumes no liability for the use or misuse of this unit.
- Wear protective clothing, gloves and eye wear when working with chemicals.
- Always direct the discharge away from people and electrical devices.
- Follow the chemical manufacturer's safe handling instructions.

TO INSTALL (REFER TO DIAGRAM ON NEXT PAGE)

- Attach appropriate 3/8" quick-disconnect fitting to swivel fitting on gun inlet. QD Plug or QD Socket with short pipe nipple, depending on existing hose connections (see diagram).
- If necessary, install the other QD on the pressure washer hose.
- Connect trigger gun to pressure washer hose with quick connect.



SCAN QR CODE FOR
OVERVIEW & SETUP VIDEO
<https://vimeo.com/515352837>

Set the chemical dilution ratio by threading one of the color coded metering tips into each chemical check valve. See chemical labels for dilution ratio recommendation or consult your chemical supplier.

- For the strongest dilution ratio do NOT install a colored metering tip.
- The dilution ratios in the metering tip chart are based on water thin chemicals with a viscosity of 1CPS.
- Thicker chemicals will require a larger tip than the ratios shown in the chart.
- Application results will ultimately determine final tip color.
- Select the tip color that is closest to your desired chemical strength and thread it into the tip holder. **DO NOT OVER-TIGHTEN.**
- Push the chemical tube over the check valve barb and place the suction tube in the chemical concentrate.
- If necessary, cut suction tube(s) to length before attaching suction strainer.

TO OPERATE

1. Two nozzles are included with the foam wand: The fan nozzle provides a wide pattern for faster coverage. The 0° nozzle provides increased foam throw distance. Install the preferred nozzle.
2. Quick connect the gun to the pressure washer hose.
3. Hold the trigger gun firmly and direct the discharge in a safe direction. Pull the trigger and begin application.
4. Make final metering tip adjustments based on application results. Try the next larger sized metering tip until the results are acceptable.
5. Maximum foam throw distance will be achieved using NO metering tip. To achieve maximum foam throw with a leaner dilution ratio, pre-dilute the chemical before drawing it through the injector.

METERING TIP SELECTION

METERING TIP COLOR	DILUTION RATIO AT GPM						
	2.5	3.0	3.5	4.0	4.5	5.0	5.5
Brown	571:1	686:1	800:1	914:1	1029:1	1143:1	1257:1
Clear	364:1	436:1	509:1	582:1	655:1	727:1	800:1
Bright Purple	232:1	278:1	325:1	371:1	417:1	464:1	510:1
White	149:1	179:1	208:1	238:1	268:1	298:1	327:1
Pink	109:1	131:1	153:1	175:1	197:1	218:1	240:1
Corn Yellow	83:1	100:1	117:1	133:1	150:1	167:1	183:1
Dark Green	66:1	79:1	92:1	105:1	118:1	131:1	144:1
Orange	55:1	67:1	78:1	89:1	100:1	111:1	122:1
Gray	53:1	64:1	75:1	85:1	96:1	106:1	117:1
Light Green	46:1	55:1	64:1	73:1	82:1	91:1	100:1
Med. Green	40:1	48:1	56:1	64:1	71:1	79:1	87:1
Clear Pink	34:1	41:1	48:1	54:1	61:1	68:1	75:1
Yellow Green	28:1	33:1	39:1	45:1	50:1	56:1	61:1
Burgundy	27:1	32:1	38:1	43:1	48:1	54:1	59:1
Pale Pink	23:1	28:1	32:1	37:1	42:1	46:1	51:1
Light Blue	21:1	25:1	30:1	34:1	38:1	42:1	46:1
Dark Purple	18:1	21:1	25:1	29:1	32:1	36:1	39:1
Navy Blue	13:1	15:1	18:1	20:1	23:1	25:1	28:1
Clear Aqua	11:1	13:1	16:1	18:1	20:1	22:1	25:1
Black	6:1	8:1	9:1	10:1	12:1	13:1	14:1
No Tip Ratio Up To:	5:1	5:1	6:1	7:1	8:1	9:1	10:1

The dilution ratios above are approximate values. Due to chemical viscosity, actual dilution ratios may vary.

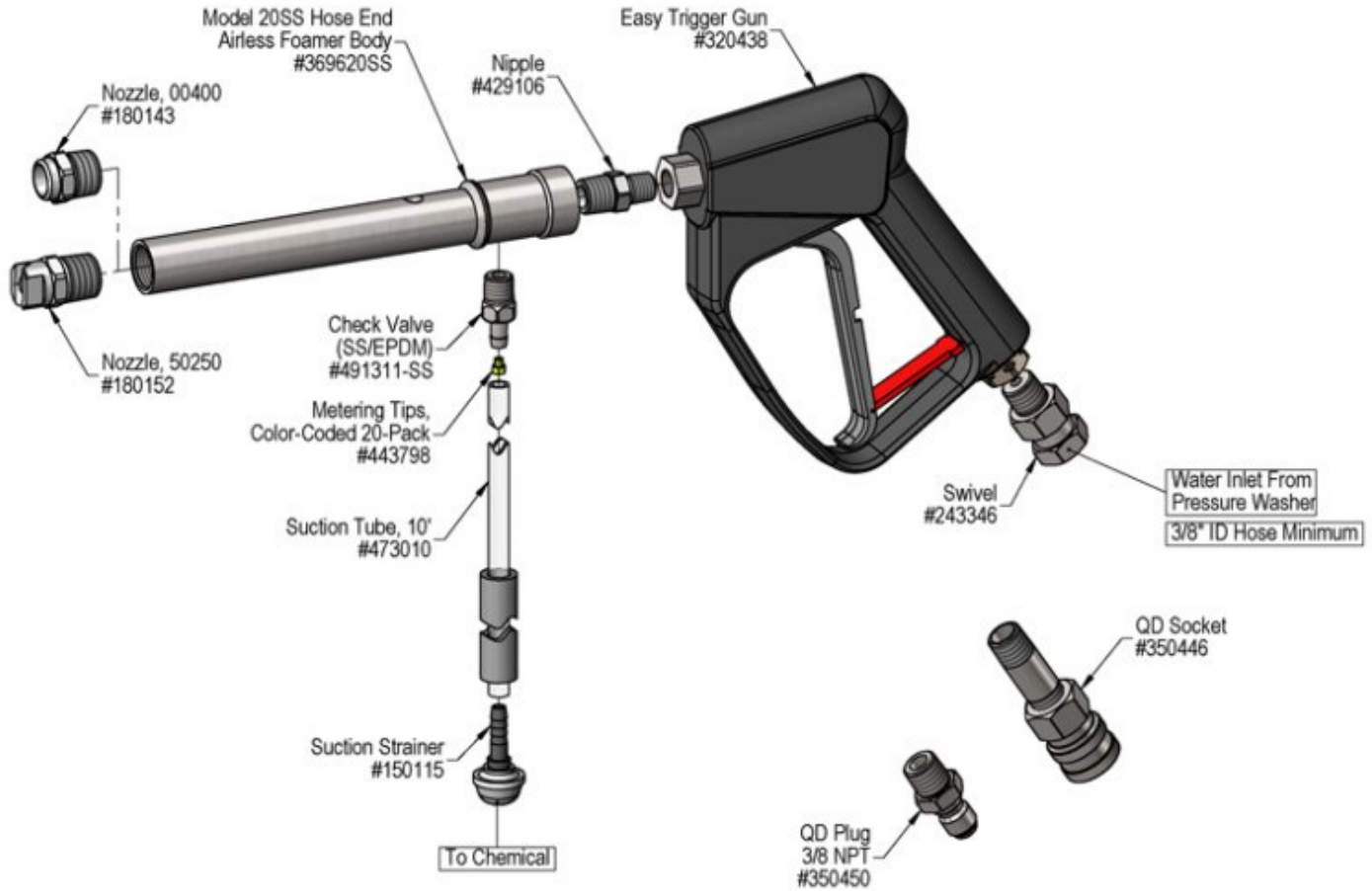

Troubleshooting Guide

Problem	Possible Cause / Solution	
	Startup	Maintenance
A) Unit will not draw chemical.	1, 2, 3	7, 8, 9, 10
B) Does not foam properly	1, 2, 4, 5, 6	7, 8, 9
C) Using too much chemical	6	

Possible Cause / Solution	
Startup	Maintenance
<ol style="list-style-type: none"> 1. GPM too low <ul style="list-style-type: none"> ◦ See requirements. 2. Water inlet clogged <ul style="list-style-type: none"> ◦ Clean the water inlet. DO NOT DRILL OUT 3. Chemical tube not immersed in chemical or depleted <ul style="list-style-type: none"> ◦ Immerse tube or replenish. 4. Ensure chemical is recommended for foaming and/or the application <ul style="list-style-type: none"> ◦ See chemical manufacturer. 5. Dilution too weak / Chemical is very thick. <ul style="list-style-type: none"> ◦ Install larger metering tip or remove metering tip. 6. Dilution too strong / No metering tip installed or wrong metering tip installed <ul style="list-style-type: none"> ◦ Install a metering tip or install a smaller metering tip. 	<ol style="list-style-type: none"> 7. Tip holder, clogged or loose. <ul style="list-style-type: none"> ◦ Clean or tighten. 8. Chemical strainer or metering tip blocked <ul style="list-style-type: none"> ◦ Clean or replace chemical strainer and/or metering tip. 9. Chemical tube stretched out where tube slides over tip holder or pin hole/cut in chemical tube (sucking air in) which reduces chemical intake <ul style="list-style-type: none"> ◦ Cut off end of tube or replace tube. 10. Hard water scale or chemical build-up may have formed in the foamer body/wand causing poor or no chemical pick-up <ul style="list-style-type: none"> ◦ Follow Preventive Maintenance instructions below, using hot water and/or descaling acid. When there is no draw at all, carefully remove inlet fitting and chemical check valve. Soak foamer body in de-scaling acid.

PREVENTIVE MAINTENANCE: When the unit will be out of service for extended periods, place chemical tube(s) in water and flush the chemical out of the unit to help prevent chemical from drying out and causing build-up. Periodically check and clean chemical strainer and replace if missing.

