

Lafferty Equipment Manufacturing, Inc. Installation & Operation Instructions

Model # 941601-LB · 1-Way Lock Box FPS Transfer System

REQUIREMENTS

Chemical Concentrate or Ready-to-Use Solution

Compressed Air up to 4 CFM per pump

OPTIONS

Stainless Steel Hose Racks

Small Stainless Steel Hose Rack # 224145

Drum & Tote Stick Lengths & Seal Materials

Drum Stick, 33" (Viton or EPDM) # 491643 / 491643-E

Drum Stick, 48" (Viton or EPDM) # 491648 / 491648-E

Drum Stick, 54" (Viton or EPDM) # 491645 / 491645-E

Tote Stick, 33" (Viton or EPDM) # 491653 / 491653-E

Tote Stick, 48" (Viton or EPDM) # 491654 / 491654-E

Tote Stick, 54" (Viton or EPDM) # 491656 / 491656-E

Alternate Seal Materials - Santoprene/EPDM Standard

Upgrade: Viton Air Pump & Viton Trigger Gun # 941600-VT

Upgrade: Kalrez Air Pump & Viton Trigger Gun # 941600-KT

Alternate Hose Discharge

Upgrade: Stainless Steel Ball Valve # 941600-X



Lafferty
EQUIPMENT MANUFACTURING INC.

www.laffertyequipment.com

501-851-2820

**WARNING! READ ALL
INSTRUCTIONS BEFORE
USING EQUIPMENT!**



OVERVIEW

The 1-Way Lock Box FPS Transfer System is for filling any sized container with chemical concentrate or ready-to-use solution. The Lock Box model features a lockable, stainless steel mounting enclosure to protect the pump and air regulator. Compressed air powers a FloJet air pump which draws chemical from the drum or tote and dispenses it through a 15 foot discharge hose and trigger gun. This unit uses a ball valve as the on/off control for the pump.

SAFETY & OPERATIONAL PRECAUTIONS

- For proper performance do NOT modify or substitute hose diameter.
- Manufacturer assumes no liability for the use or misuse of this unit.
- Wear protective clothing, gloves and eye-wear when working with chemicals.
- Always direct the discharge away from people and electrical devices.
- Follow the chemical manufacturer's safe handling instructions.
- DO NOT use d-Limonene or other chemicals that are not compatible with the Santoprene diaphragms.
- Viton or Kalrez upgrades are available.

TO INSTALL (REFER TO DIAGRAM ON NEXT PAGE)

1. Mount the unit above solution supply level to prevent siphoning.
2. Place the strainer in the chemical solution(s).
3. Attach the discharge hose.
4. Attach a compressed airline to the air inlet ball valve. DO NOT TURN ON.
5. Air Filter/Dryer recommend.

TRIGGER GUN

1. Hold the trigger gun, open the inlet air ball valve, place the nozzle in the container to be filled. Pull the trigger and begin.
2. When container is filled to the desired level, release the trigger. Close the inlet ball valve and pull the trigger to relieve pressure in the hose.

BALL VALVE

1. Make sure the discharge ball valve is closed and in hand.
2. Open the inlet ball valve, place the wand in the container to be filled then open the discharge ball valve to begin filling container.
3. When container is filled to the desired level, close the valve then close the inlet ball valve and relieve pressure in the hose.

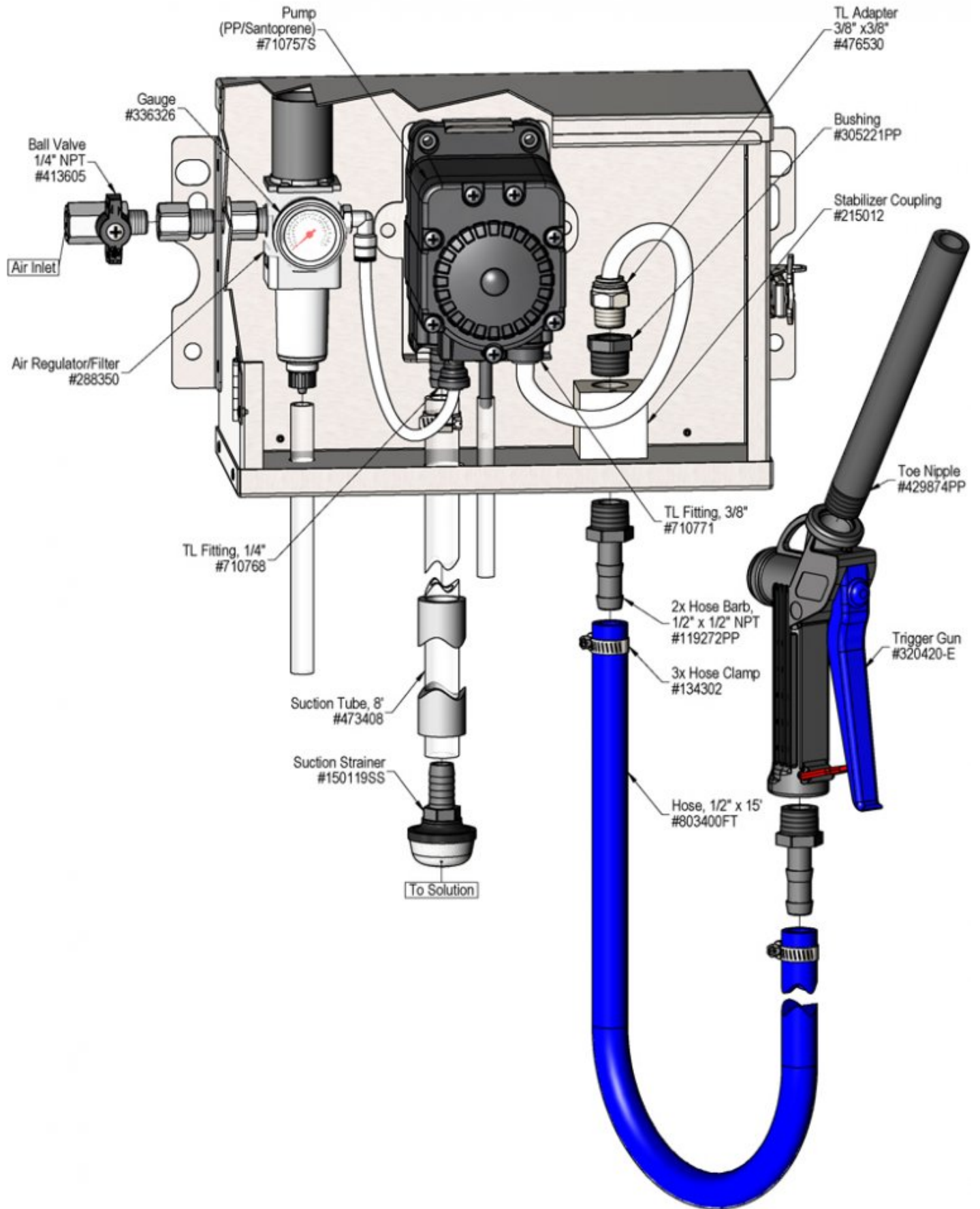

Troubleshooting Guide

Problem	Possible Cause / Solution	
	Startup	Maintenance
A) Air pump will not run or pump chemical solution.	1,3,4	5,6,9,10
B) Will not draw chemical.	1,2,3	6,7,8
C) Pump runs too fast with no output.	2	6,7,8,9

Possible Cause / Solution	
Startup	Maintenance
<ol style="list-style-type: none"> 1. Inlet ball valve partially closed or air pressure too low. <ul style="list-style-type: none"> ◦ Completely open air inlet ball valve. 2. Chemical tube not immersed in container or container empty <ul style="list-style-type: none"> ◦ Immerse tube or replenish. 3. Hose kinked <ul style="list-style-type: none"> ◦ Straighten the hose. 4. Ice particles from condensation in air line — Air pump can periodically "freeze up" (stall) due to ice particles in the pump's exhaust (depending on air humidity & other factors) <ul style="list-style-type: none"> ◦ WAIT several seconds to allow the ice particles to melt and blow out, at which time the pump will automatically resume pumping. 	<ol style="list-style-type: none"> 5. Air regulator clogged or failed <ul style="list-style-type: none"> ◦ Clean or replace. 6. Chemical strainer clogged up <ul style="list-style-type: none"> ◦ Clean or replace. 7. Vacuum leak in suction line. <ul style="list-style-type: none"> ◦ Tighten the connection(s). 8. Chemical tube stretched out where tube attaches or pin hole/cut in tube sucking air. <ul style="list-style-type: none"> ◦ Cut off end of tube or replace tube. 9. Problem with air pump <ul style="list-style-type: none"> ◦ Refer to air pump instruction manual. ◦ https://www.xylem.com/en-us/brands/Flojet/flojet-products/g57-air-operated-double-diaphragm-pump ◦ Replace pump. 10. Use of an oiler in the airline will cause pump to stall <ul style="list-style-type: none"> ◦ Use only clean, dry air.

PREVENTIVE MAINTENANCE: When the unit will be out of service for extended periods, place chemical tube(s) in water and flush the chemical out of the unit to help prevent chemical from drying out and causing build-up. Periodically check and clean chemical strainer and replace if missing.

