

Lafferty Equipment Manufacturing, LLC Installation & Operation Instructions

Model # 976901-LB · Sentry Secure Hand Sanitizer Dispenser

REQUIREMENTS

Dimensions

Total Height	44 in.
Height to Spray Head	41 in.
Dispenses per Gallon	Adjustable



www.laffertyequipment.com

501-851-2820

**WARNING! READ ALL
INSTRUCTIONS BEFORE
USING EQUIPMENT!**



OVERVIEW

The Sentry Secure Hand Sanitizer Dispenser is a hands free, all stainless steel dispenser for gel and liquid hand hygiene products (sanitizer or soap). Foot pedal activation eliminates contamination due to hand contact, and a stainless steel mechanical pump sprays a field-adjustable amount of product into the users hand. The industrial design allows free-standing operation or permanent installation, and a lockable enclosure secures product to prevent tampering and theft. Perfect for dispensing hand sanitizer in food preparation areas, hospitals, military facilities, retail store entrances, and countless other locations.

SAFETY & OPERATIONAL PRECAUTIONS

- Manufacturer assumes no liability for the use or misuse of this unit.
- Follow the chemical manufacturer's safe handling instructions.

TO INSTALL (REFER TO DIAGRAM ON NEXT PAGE)

1. The Sentry can be either free-standing for portability or bolted to the floor for permanent positioning.
2. Place the container of sanitizing solution in the chemical enclosure
3. Remove shipping lid, and thread the included jug lid (with short tube and strainer) onto the container of the sanitizing or soap solution.
4. Attach the suction tube to the jug lid hose barb.
5. Prime the unit by repeatedly stepping on the foot pedal until it begins to spray. Initial priming takes approximately 25 strokes, but varies based on the viscosity of the sanitizing solution.
6. Once primed, adjust output volume with the Adjustment Bolt, using the Locking Nut to hold it in place.
 - Tighten (clockwise) to dispense less product — more dispenses per gallon.
 - Loosen (counter-clockwise) to dispense more product — fewer dispenses per gallon.

TO OPERATE

1. Place hands under nozzle and step on foot pedal.



How to Replace the Piston O-Ring

1. Remove the top and back of the base.
2. Remove nozzle and nozzle check valve.
3. Remove screws on top of the pump body.
4. Pull the pump assembly back.
5. Twist and pull up the pump body & replace the O-ring.
6. Press piston back into pump body and re-assemble.

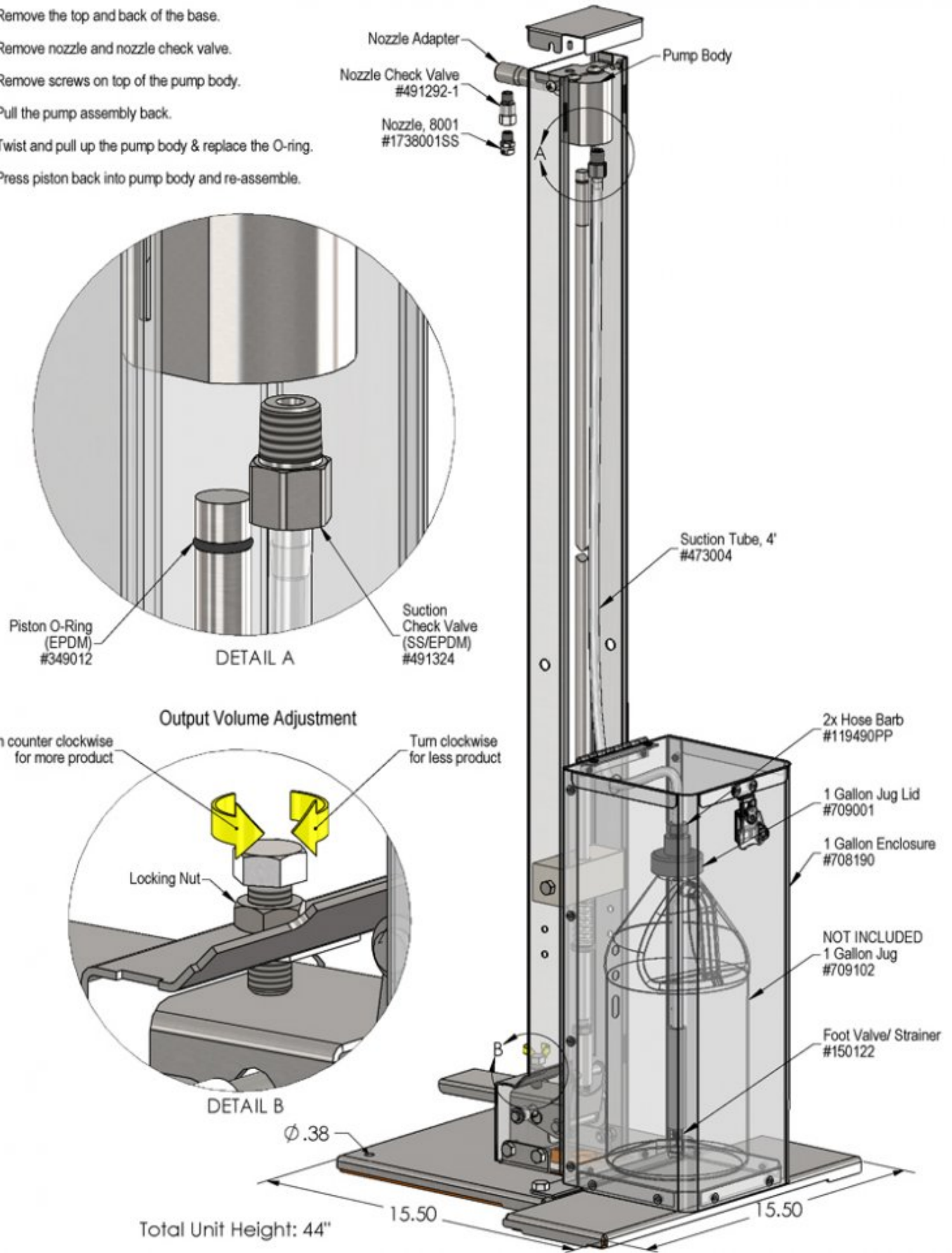

Troubleshooting Guide

Problem	Possible Cause / Solution	
	Startup	Maintenance
A) Will not draw or spray	1, 2	6, 8, 9, 10
B) Dispensing too little	3, 5	7, 9
C) Dispensing too much	4, 5	
D) Dispenses inconsistent amount	5	9

Possible Cause / Solution	
Startup	Maintenance
<ol style="list-style-type: none"> 1. The unit needs to be primed. <ul style="list-style-type: none"> ◦ Step on foot pedal repeatedly until it sprays (approximately 25 pumps). ◦ Make sure tubing connections are tight. 2. Chemical tube not immersed in sanitizer solution or sanitizer depleted. <ul style="list-style-type: none"> ◦ Fully immerse tube or replenish. 3. Need to increase output volume. <ul style="list-style-type: none"> ◦ Loosen locking nut, turn adjustment bolt counter-clockwise, tighten locking nut. 4. Need to decrease output volume. <ul style="list-style-type: none"> ◦ Loosen locking nut, turn adjustment bolt clockwise, tighten locking nut. 5. Locking nut loose <ul style="list-style-type: none"> ◦ Check locking nut. Tighten if loose. 	<ol style="list-style-type: none"> 6. Suction check valve stuck or failed. <ul style="list-style-type: none"> ◦ Clean or replace. 7. Foot valve / strainer partially blocked. <ul style="list-style-type: none"> ◦ Clean or replace foot valve / strainer. 8. Chemical tube stretched out or pin hole/cut in tube (sucking in air). <ul style="list-style-type: none"> ◦ Remove tube from hose barb, and cut off 1/2" of tube. ◦ Reattach tube to hose barb or replace entire tube. 9. Chemical build-up may have formed or dried out in the nozzle. <ul style="list-style-type: none"> ◦ Insert small brush or pin into nozzle (without removing it) to remove dried chemical. Press pedal firmly to blow out. ◦ Follow Preventive maintenance instructions below, using hot water to remove chemical build up. 10. Piston O-ring may have worn after prolonged use. <ul style="list-style-type: none"> ◦ Replace. See Diagram.

When the unit will be out of service for extended periods, remove tube and place in water. Operate the foot pedal until water is coming out of the nozzle for several seconds to clear out chemical and help prevent chemical build-up. Check chemical strainer and clean or replace as needed.



SCAN QR CODE FOR DETAILED SENTRY MAINTENANCE INFORMATION

<https://learning.laffertyequipment.com/sentry-maintenance/>

