

# Lafferty Equipment Manufacturing, Inc. Installation & Operation Instructions

Model # 940119-BLUE · Portable 2-Wheel 20 Gallon Liberty Sprayer, Blue

## REQUIREMENTS

Ready-to-Use Chemical Solution

Compressed Air	up to 4 CFM
Hose	1/2" ID x 50'
Nozzle	2506 or 2510

## OPTIONS

Alternate Seal Materials - Santoprene Standard

Viton Upgrade: Flojet Air Pump & Check Valves	# 710756
Kalrez Upgrade: Flojet Air Pump & Check Valves	# 710755

Proportioning / Filling Options

1-Way Ball Valve Mixing Station (4 GPM)	# 985100
1-Way Push Lever Mixing Station (4 GPM)	# 981100
High Volume Mixing Station (9.9 GPM)	# 985835

## WEIGHT & DIMENSIONS

Single Package	
Shipping Weight	64 lbs.
Shipping Dimensions	42" x 23" x 21"



**Lafferty**  
EQUIPMENT MANUFACTURING INC.

[www.laffertyequipment.com](http://www.laffertyequipment.com)

501-851-2820

**WARNING! READ ALL  
INSTRUCTIONS BEFORE  
USING EQUIPMENT!**



## OVERVIEW

The Portable 2-Wheel 20 Gallon Liberty Sprayer is a chemical spray applicator for projecting ready-to-use chemical solution on to a variety of surfaces. This unit features a stainless steel enclosure and cart and uses a cost-effective Flojet air-operated, double-diaphragm pump to draw pre-diluted chemical from the 20 gallon tank. The solution is then discharged through the hose, wand and fan pattern spray nozzle. Includes 2 spray nozzles providing either 16 or 28 minutes of spraying time per 20 gallons of solution depending on the nozzle used.

## SAFETY & OPERATIONAL PRECAUTIONS

- For proper performance do NOT modify, substitute nozzle, hose diameter or length
- Manufacturer assumes no liability for the use or misuse of this unit.
- Wear protective clothing, gloves and eye-wear when working with chemicals.
- Always direct the discharge away from people and electrical devices.
- Follow the chemical manufacturer's safe handling instructions.
- DO NOT use d-Limonene or other chemicals that are not compatible with the Santoprene diaphragms.
- Viton upgrade is available.

## TO INSTALL (REFER TO DIAGRAM ON NEXT PAGE)

1. Fill the tank with ready to use solution to the desired level. Replace lid.
2. Attach a compressed airline to the inlet ball valve. DO NOT TURN ON
3. Air Filter/Dryer recommend.

## TO OPERATE

- **Always** make sure the discharge ball valve is closed or pointed in a safe direction before turning the air on. Ball valve can be shut off at any time during operation but should not be left unattended for long periods of time.
  - The unit has been tested and is ready to operate, the air pressure preset at 60 PSI. This is the optimum pump pressure. Test "as is" before making any adjustments.
  - 2 nozzles are provided a 2506 (.7 GPM) and a 2510 (1.2 GPM). Select one and install it.
1. With the wand in hand direct the discharge in a safe direction and open the discharge ball valve and the air ball valve.
  2. Wait several seconds for pump to prime. IF after 30 seconds the pump hasn't primed turn off the air, remove the suction tube and fill with water and replace. Once the diaphragms are wet priming is not an issue. Open air ball valve to resume set up.
  3. When spraying is complete:
    - Close the discharge ball valve.
    - Promptly return to the unit and close the air ball valve.
    - Briefly re-open the discharge ball valve to relieve pressure in the hose.
    - Store the hose on optional hose rack.
  4. Rinse the work surface before the spray dries.

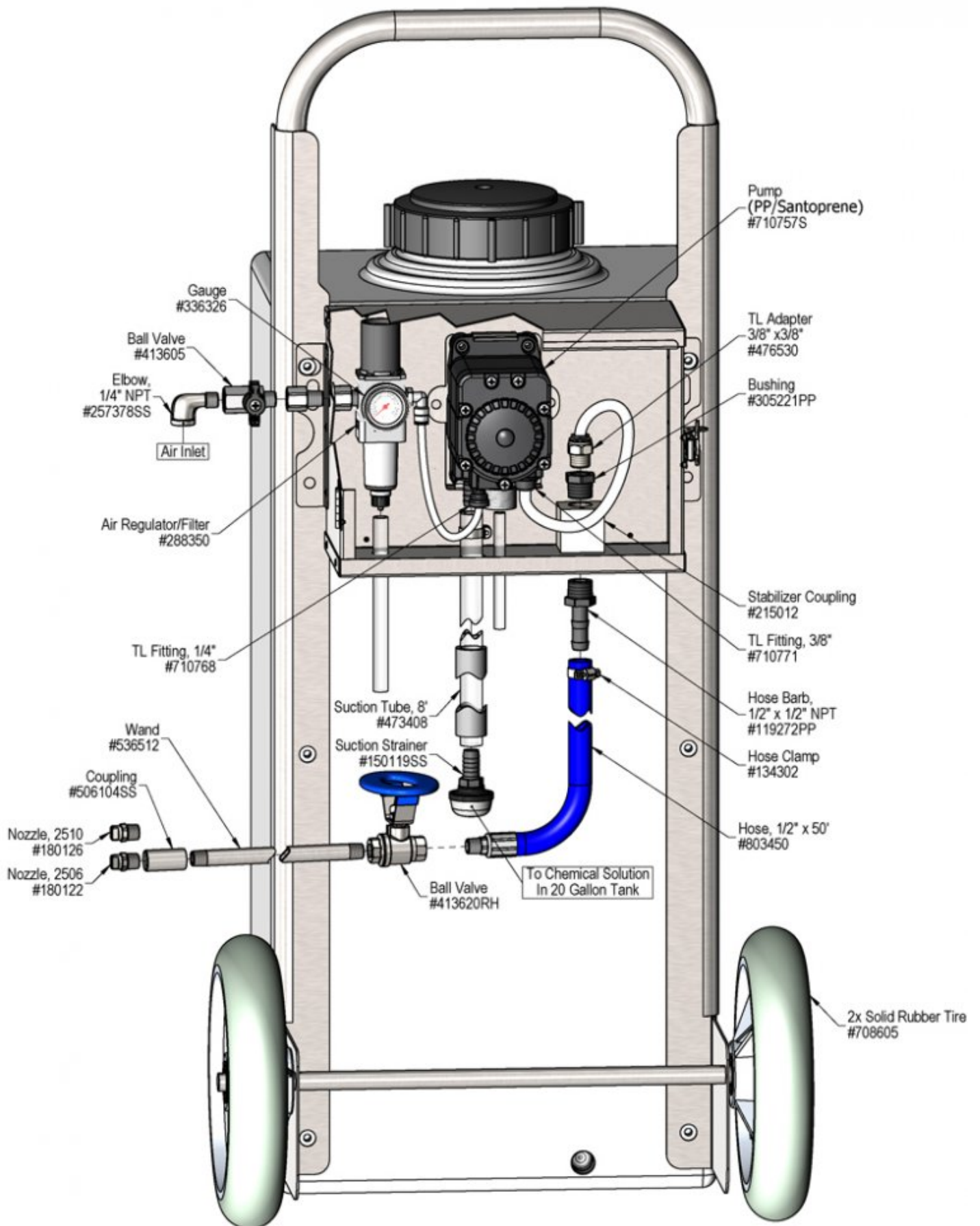

## Troubleshooting Guide

Problem	Possible Cause / Solution	
	Startup	Maintenance
A) Air pump will not run or pump solution. B) Will not draw chemical. C) Pump runs too fast with no output.	1,3,4 1,2,3 2	5,6,9,10 6,7,8 6,7,8,9

Possible Cause / Solution	
Startup	Maintenance
<ol style="list-style-type: none"> <li><b>1. Inlet ball valve partially closed or air pressure too low.</b> <ul style="list-style-type: none"> <li>◦ Completely open air inlet ball valve.</li> </ul> </li> <li><b>2. Chemical tube not immersed in container or container empty</b> <ul style="list-style-type: none"> <li>◦ Immerse tube or replenish.</li> </ul> </li> <li><b>3. Discharge ball valve closed or hose kinked</b> <ul style="list-style-type: none"> <li>◦ Open ball valve / Straighten the hose.</li> </ul> </li> <li><b>4. Ice particles from condensation in air line — Air pump can periodically "freeze up" (stall) due to ice particles in the pump's exhaust (depending on air humidity &amp; other factors)</b> <ul style="list-style-type: none"> <li>◦ WAIT several seconds to allow the ice particles to melt and blow out, at which time the pump will automatically resume pumping.</li> </ul> </li> </ol>	<ol style="list-style-type: none"> <li><b>5. Air regulator clogged or failed</b> <ul style="list-style-type: none"> <li>◦ Clean or replace.</li> </ul> </li> <li><b>6. Chemical strainer clogged up</b> <ul style="list-style-type: none"> <li>◦ Clean or replace.</li> </ul> </li> <li><b>7. Vacuum leak in suction line.</b> <ul style="list-style-type: none"> <li>◦ Tighten the connection(s).</li> </ul> </li> <li><b>8. Chemical tube stretched out where tube attaches or pin hole/cut in tube sucking air.</b> <ul style="list-style-type: none"> <li>◦ Cut off end of tube or replace tube.</li> </ul> </li> <li><b>9. Problem with air pump</b> <ul style="list-style-type: none"> <li>◦ Refer to air pump instruction manual.</li> <li>◦ <a href="https://www.xylem.com/en-us/products-services/pumps-packaged-pump-systems/pumps/positive-displacement-pumps2/diaphragm-pumps/air-operated-diaphragm-pumps/g57-air-operated-double-diaphragm-pump/documentation/">https://www.xylem.com/en-us/products-services/pumps-packaged-pump-systems/pumps/positive-displacement-pumps2/diaphragm-pumps/air-operated-diaphragm-pumps/g57-air-operated-double-diaphragm-pump/documentation/</a></li> <li>◦ Replace pump.</li> </ul> </li> <li><b>10. Use of an oiler in the airline will cause pump to stall</b> <ul style="list-style-type: none"> <li>◦ Use only clean, dry air.</li> </ul> </li> </ol>

**PREVENTIVE MAINTENANCE:** When the unit will be out of service for extended periods, place chemical tube(s) in water and flush the chemical out of the unit to help prevent chemical from drying out and causing build-up. Periodically check and clean chemical strainer and replace if missing.

