

Lafferty Equipment Manufacturing, LLC Installation & Operation Instructions

Model # 950011 · 633 1-Way Pump Fed Fogger

REQUIREMENTS

Ready-to-Use Chemical Solution	
Temperature	up to 160°F
Pressure	20 to 35 PSI
Compressed Air	
	up to 3.7 CFM @ 80 PSI
Minimum Air Supply Line	1/2"

OPTIONS

Electronic Zone Control	
3-Zone PF Fogger PLC Vision Controller	# 950843
6-Zone PF Fogger PLC Vision Controller	# 950846
Zone Control Kit	# 950850
Metered Bleed Assembly	# 950852
Alternate Check Valve (Viton Standard)	
TL Check Valve, PVC / EPDM, 3/8"	# 491456-E

WEIGHT & DIMENSIONS

Single Package	
Shipping Weight	2 lbs.
Shipping Dimensions	15" x 8" x 5"



www.laffertyequipment.com

501-851-2820

**WARNING! READ ALL
INSTRUCTIONS BEFORE
USING EQUIPMENT!**



OVERVIEW

The 633 1-Way Pump Fed Fogger is a damp mist sprayer that receives ready-to-use chemical solution from a central pump system and uses compressed air (3.7 CFM @ 80 PSI) to project it up to 15 feet. The adjustable output sprays mist (fog) into the air to cover exposed surfaces and penetrate hard-to-reach areas.

SAFETY & OPERATIONAL PRECAUTIONS

- Manufacturer assumes no liability for the use or misuse of this unit.
- Wear protective clothing, gloves and eye-wear when working with chemicals.
- Always direct the discharge away from people and electrical devices.
- Follow the chemical manufacturer's safe handling instructions.
- Carefully follow chemical manufacturer's safe handling instructions and recommended precautions/practices when using flammable chemicals.
- **CAUTION: Foggers atomize chemical into the air. Ensure that the area to be fogged has been evacuated of all people and/or animals before commencing chemical fogging operation. Upon completion of fogging, ensure that sufficient time has elapsed for all the fog to have dissipated before returning to the area without proper respiratory protection.**
- **SPECIAL CAUTION: When fogging with off-gassing chemicals, such as peracetic acid, a Metered Bleed Assembly is required. This relieves pressure in the solution line when fogging has been completed and can be installed at any convenient point within each zone.**

PUMP FED 633 1-WAY FOGGER

PROJECTS DAMP FOG/MIST UP TO 15'

COMPRESSED AIR FLOW (CFM)

PLUMES	60 PSI	80 PSI
1-Way	3.0	3.7

TO INSTALL (REFER TO DIAGRAM ON NEXT PAGE)

1. Pump Fed Foggers can be plumbed into single or multiple zones.
2. Each zone can include a combination of 1-Way, 2-Way, 4-Way or 8-Way Pump Fed Foggers. The number of foggers which can be run on each zone will depend on the volume (CFM) of compressed air available. (See Requirements) For practical purposes, a zone is typically limited to a maximum of four 8-Way foggers or eight 4-Way foggers (or equivalent)
3. Foggers may be mounted on equipment or suspended or below a ceiling. If suspended from a ceiling, make sure the foggers are at least 14" below the ceiling to avoid the fog plume directly hitting the ceiling, interfering with the fogging action and causing dripping onto surfaces below.

TO OPERATE

FOR MANUAL OPERATION

To Adjust the fog consistency needle valve, test with WATER ONLY prior to any chemical use!

1. Completely close the solution needle valves on each fogger and then open 1 ½ turns.
2. Connect a city water pressure (35 psi) supply to the chemical solution line and compressed air to the air line.
3. Turn on air and water supply.
4. Observe fog volume/density.
5. Either: Turn off air and water supply and adjust each solution needle valve to produce fog of the desired density.
Or: While the fogger is running adjust each solution needle valve.
6. Turn off air and water supply and disconnect from zone.
7. Connect each zone to a central chemical solution feed system, compressed air and manual controls.

FOR USE WITH A VISION CONTROLLER

To Adjust the fog consistency needle valve, test with WATER ONLY prior to any chemical use!

1. When the foggers are to be controlled by a Vision Controller (3-Zone or 6-Zone), each zone requires a Zone Control Kit.
2. Install the air and chemical solenoids from the Zone Control Kit at the start of each zone.
3. Completely close the RTU solution needle valves on each fogger and then open 1 ½ turns.
4. Connect a separate city water pressure (35 psi) supply to the chemical solution line and compressed air to the air line.
5. Program fogger controller for required operation.
6. Turn on air and water supply and activate solenoids.
7. Observe fog volume/density.
8. Either: Turn off air and water supply and adjust each solution needle valve to produce fog of the desired density.
Or: While the fogger is running adjust each solution needle valve.
9. Turn off air and disconnect water supply from zone.
10. Connect each zone to a central chemical solution feed system, compressed air and to your choice of Vision fogger controller. See Vision Control instructions for setup.

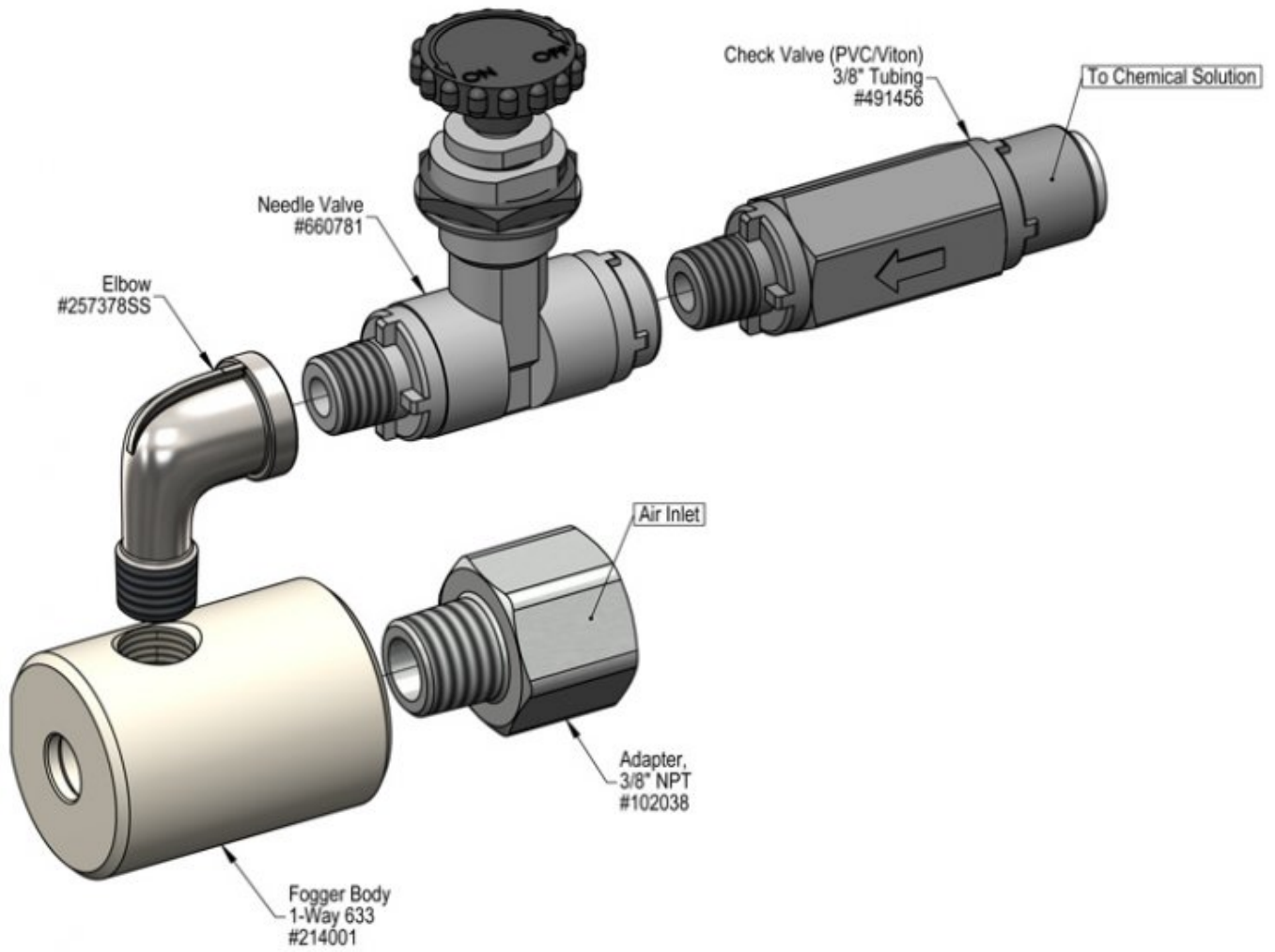

Troubleshooting Guide

Problem	Possible Cause / Solution	
	Startup	Maintenance
A) Fogger sputtering or fog not acceptable	1, 2, 3	6
B) Fog is too wet	1, 3, 4, 5	6
C) Fogger head drips slightly after solenoid shuts off		7

Possible Cause / Solution	
Startup	Maintenance
<ul style="list-style-type: none"> 1. Not enough air pressure or volume <ul style="list-style-type: none"> ◦ See REQUIREMENTS, page 1. 2. Air pressure too high. <ul style="list-style-type: none"> ◦ Slightly close the air supply valve to lower the pressure by lowering the volume until the fogger smooths out. 3. Air line too small <ul style="list-style-type: none"> ◦ See REQUIREMENTS, page 1. 4. Solution pressure is too high <ul style="list-style-type: none"> ◦ Lower the solution pressure. 5. Drawing too much solution <ul style="list-style-type: none"> ◦ Adjust the needle valve, counter clockwise for wetter fog clockwise for dryer. 	<ul style="list-style-type: none"> 6. Debris closing air inlet(s) of fogger <ul style="list-style-type: none"> ◦ Disconnect air supply and visually inspect; remove debris from fogger inlet(s). 7. Solution pressure on the fogger head needs to drop below 7 PSI for check valve spring to activate <ul style="list-style-type: none"> ◦ This is normal operation of the system. When fogging sanitizing chemicals this causes no issues. ◦ If this small amount (10-15 ml) poses problems with plant processing, then a small collector should be placed under each fogger head

PREVENTIVE MAINTENANCE: When the unit will be out of service for extended periods, place chemical tube(s) in water and flush the chemical out of the unit to help prevent chemical from drying out and causing build-up. Periodically check and clean chemical strainer and replace if missing.

