

Lafferty Equipment Manufacturing, LLC Installation & Operation Instructions

Model # 950802 · Fogger Single Cycle Controller - 460 CFM

REQUIREMENTS

Electric	120V / 2 Amps
Compressed Air	Up to 460 CFM



www.laffertyequipment.com

501-851-2820

**WARNING! READ ALL
INSTRUCTIONS BEFORE
USING EQUIPMENT!**



OVERVIEW

When activated, the Fogger Single Cycle Controller starts fogger operation immediately and runs for a predetermined period of time — up to 2.84 hours — then switches off. The run time is set by selecting toggle switches that total the number of seconds of desired application time. The total air CFM requirement of all the foggers connected to this controller must be less than 460 CFM, which is the air CFM capacity of the controller's 3/4 inch solenoid. (For a lower air capacity requirement of 180 CFM and below, see controller model #950800.)

SAFETY & OPERATIONAL PRECAUTIONS

- See Additional Safety Precautions included with the Electrical Control Box Installation Information
- Always consider electrical shock hazard when working with and handling electrical equipment. If uncertain, consult an Electrician. Electrical wiring should only be done by a qualified Electrician, per Local and State Electrical Codes.
- Manufacturer assumes no liability for the use or misuse of this unit.
- Wear proper respiratory protection, protective clothing, gloves and eye-wear when working with chemicals.
- Always direct the discharge away from electrical devices.
- Carefully follow chemical manufacturer's safe handling instructions and recommended precautions/practices especially when using flammable chemicals.
- For proper performance do NOT modify electrical control box.
- Disconnect electrical power to the control box prior to opening it.
- Remove any packing material from inside the control box before operating.
- **SPECIAL CAUTION: This fogger atomizes chemical into the air. Ensure that the chemical is safe to be around or the area to be fogged has been evacuated of all people and/or animals before starting fogging. Upon completion of fogging, ensure that sufficient time has elapsed for all the fog to have dissipated before returning to the area without proper respiratory protection.**

TO INSTALL (REFER TO DIAGRAM ON NEXT PAGE)

1. Mount the control box to a secure surface. It may be mounted vertically, on a wall, post or other vertical surface, or horizontally on a flat surface. Commercially available mounting hardware (not provided), appropriate to the surface material of construction, should be used to secure the control box to the surface. Mounting holes are located at the four corners of the base of the control box.
2. Do NOT connect to electricity yet.
3. Connect your compressed air to the 3/4" solenoid in the direction of the arrow and connect the discharge to piping leading to the fogger head(s)

TO OPERATE

TIMER ADJUSTMENT

1. To set the timer, press down on the right side of the dip switches (the "on" position) so that the combination of "on" switches equals the required fogging time.
 - The number to the left of each switch indicates the number of seconds each switch controls.
 - The total run time equals the total seconds of all switches in the ON position (maximum run time - 2.84 hours).
 - For proper operation, every dip switch must be set fully to either OFF or ON (to the left or to the right), not in a middle position.
2. Replace control box cover and set the front rocker switch to the OFF position, then plug the power cord into a 120 VAC power outlet (GFI recommended).
 - **Note:** If power is interrupted while the unit is operating, the system stops all timer operations. To restart, set the controller switch to Off and then return the switch to AUTO. Compressed Air flow will start immediately when the switch is set to AUTO.
3. Read and follow the Installation and Operation Instructions for the Fogger(s) that will be controlled by this timer.

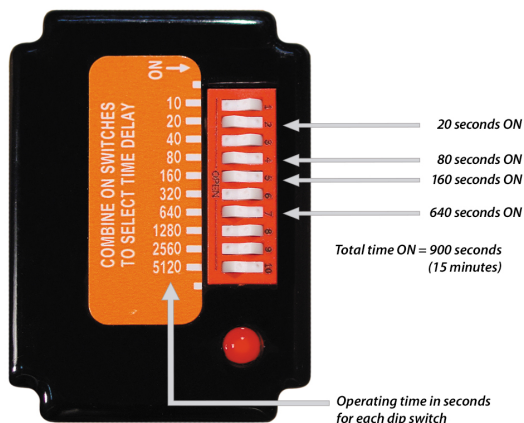

Controller Rocker Switch Settings



AUTO / ON – Press here: Timed fogging begins when pressed and ends based on timer settings (one cycle). Green LED illuminates and stays on. • Switch must be reset before another cycle of timed fogging can start.

OFF / RESET – Set switch to mid-point; green LED is dark

MANUAL ON – Press here and hold: Fogging is immediate and continues as long as switch is pressed. When released, switch returns to OFF / RESET position.

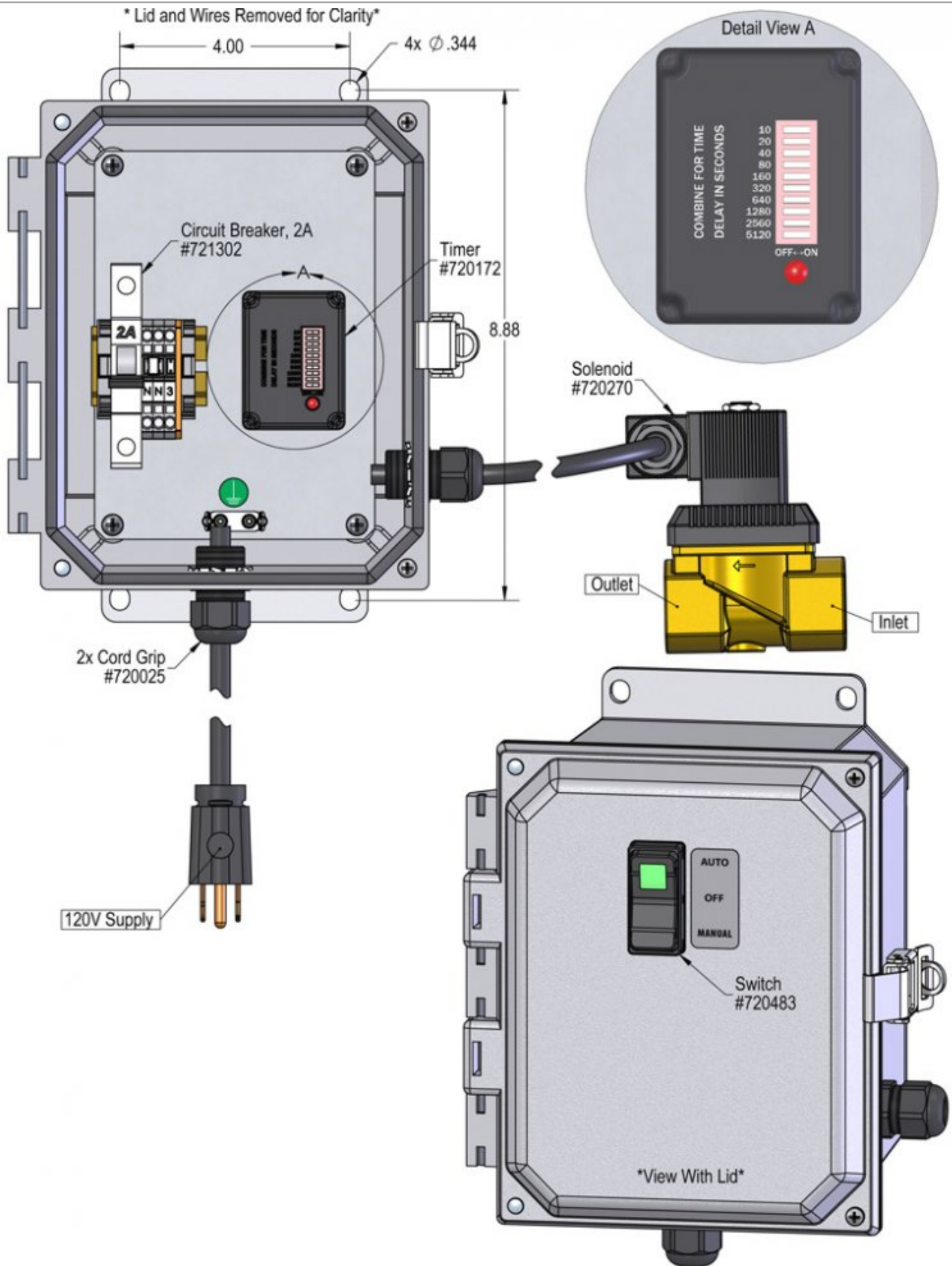

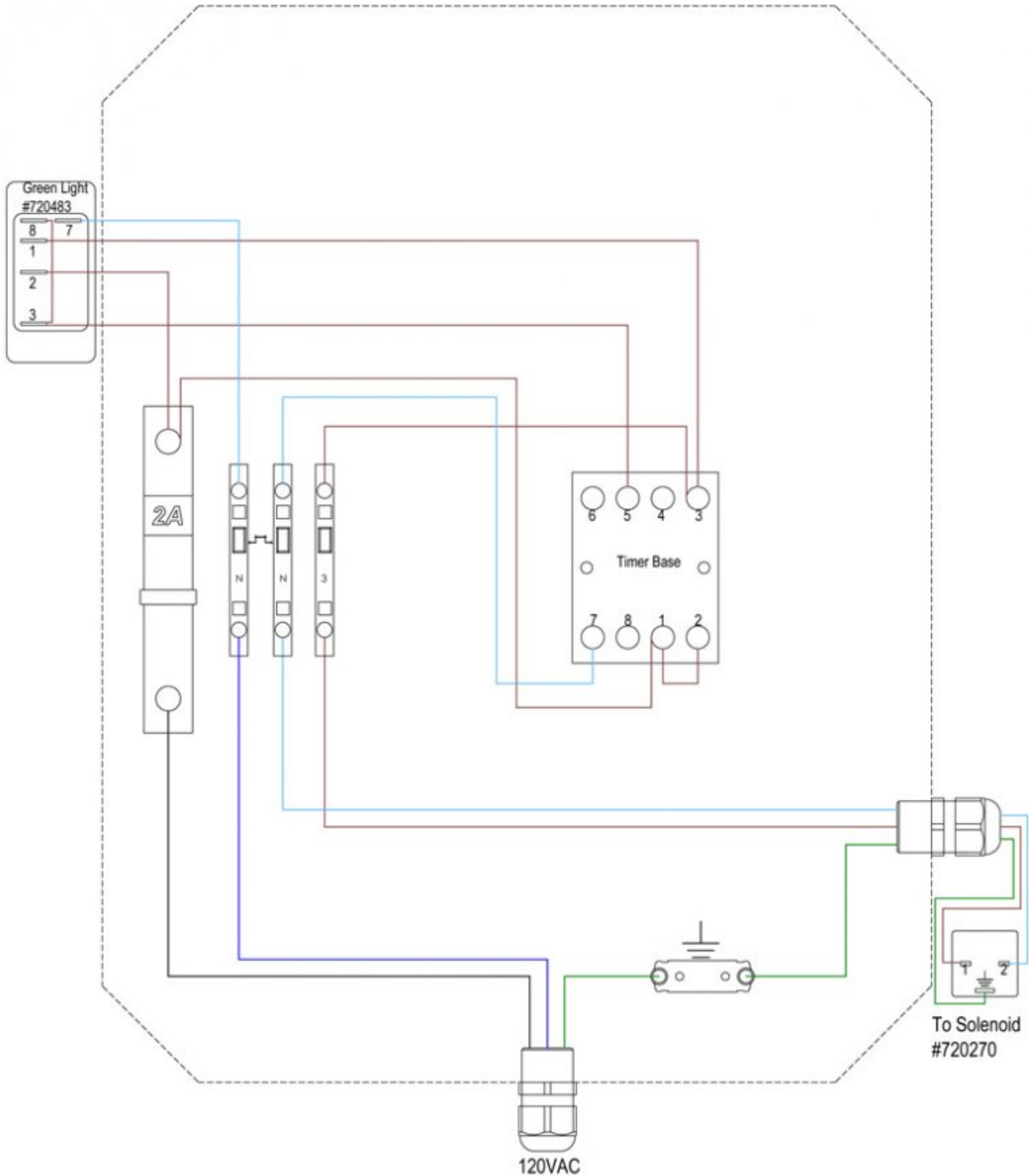

REVISIONS			
REV.	DESCRIPTION	DATE	APPROVED
00	950802 Added to SolidWorks	3/16/2016	HB
01	Switched Breaker & Terminal Strip	1/31/2018	HB

