

# Lafferty Equipment Manufacturing, Inc. Installation & Operation Instructions

Model # 917907 · 2-Way A-20SS Airless Foamer

## REQUIREMENTS

### Chemical Concentrate

#### Water

Temperature	up to 180°F
Pressure	400 to 1000 PSI
Flow	3.1 GPM @ 700 PSI
Supply Line	3/8"

Hose	3/8" ID x 50'
------	---------------

Nozzle	A-20 Airless Foam Wand
--------	------------------------

## OPTIONS

### Stainless Steel Hose Racks

Large Stainless Steel Hose Rack	# 224150
---------------------------------	----------

### Stainless Steel Jug Racks

Jug Rack, SS, 1 Gallon, Round/Square	# 224200
Jug Rack, SS, 2 1/2 Gallon	# 224210
Jug Rack, SS, 5 Gallon, Round/Square	# 224215

### Safe Flow Lid™ for 1 Gallon Jugs

Lid, Suction Tube, and Strainer	# 709101
---------------------------------	----------

### Alternate Check Valve - EPDM Standard

Check Valve, Chemical, PP/Viton, 1/4"	# 491315
---------------------------------------	----------

## WEIGHT & DIMENSIONS

### Single Package

Shipping Weight	24 lbs.
Shipping Dimensions	28" x 19" x 8"



**Lafferty**  
EQUIPMENT MANUFACTURING INC.

[www.laffertyequipment.com](http://www.laffertyequipment.com)  
501-851-2820

**WARNING! READ ALL  
INSTRUCTIONS BEFORE  
USING EQUIPMENT!**



## OVERVIEW

The 2-Way A-20SS Airless Foamer is a 3.1 GPM @ 700 PSI foam applicator for projecting up to 2 foaming chemicals on to any surface up close or at a distance without compressed air. This stainless steel venturi injection system uses high water pressure (400 - 1000 PSI) to draw and blend chemical concentrates into the water stream to create accurately diluted solutions. The solutions then flow through the foam hose and trigger gun to the "airless" foam wand which draws in atmospheric air to create and project wet, clinging foam at distances up to 12 feet. Use the ball valves to inject the 2 chemicals separately or simultaneously.

**SAFETY & OPERATIONAL PRECAUTIONS**

- For proper performance do NOT modify, substitute nozzle, hose diameter or length.
- Manufacturer assumes no liability for the use or misuse of this unit.
- Wear protective clothing, gloves and eye wear when working with chemicals.
- Always direct the discharge away from people and electrical devices.
- Follow the chemical manufacturer's safe handling instructions.

**TO INSTALL (REFER TO DIAGRAM ON NEXT PAGE)**

If you are connecting to a potable water supply follow all local codes for backflow prevention.

1. Mount the unit to a suitable surface above the chemical supply to prevent siphoning.
2. Connect hose(s) as shown in the diagram.
3. Flush any new plumbing of debris before connecting water.
4. Connect water supply. Install a water filter if water piping is older or has known contaminants.

Set the chemical dilution ratio by threading one of the color coded metering tips into each chemical check valve. See chemical labels for dilution ratio recommendation or consult your chemical supplier.

- For the strongest dilution ratio do NOT install a colored metering tip.
- The dilution ratios in the metering tip chart are based on water thin chemicals with a viscosity of 1CPS.
- Thicker chemicals will require a larger tip than the ratios shown in the chart.
- Application results will ultimately determine final tip color.
- Select the tip color that is closest to your desired chemical strength and thread it into the tip holder. **DO NOT OVER-TIGHTEN.**
- Push the chemical tube over the check valve barb and place the suction tube in the chemical concentrate.
- If necessary, cut suction tube(s) to length before attaching suction strainer.

**TO FOAM**

1. A fan nozzle for fast coverage or a zero degree nozzle for distance are included.
2. Select and install the nozzle you want to use in the foam wand.
3. Make final metering tip adjustments based on foam quality and cleaning results.
4. With trigger gun in hand open the inlet ball valve and 1 chemical ball valve.
5. Pull the trigger and begin application.
6. When application is completed, release the trigger then close the inlet ball valve and the chemical ball valve.
7. Briefly squeeze the trigger to relieve pressure in hose.

**METERING TIP SELECTION**

METERING TIP COLOR	OZ/MIN	DILUTION RATIO @ 700 PSI
Brown	0.56	711:1
Clear	0.88	452:1
Bright Purple	1.38	288:1
White	2.15	185:1
Pink	2.93	136:1
Corn Yellow	3.84	104:1
Dark Green	4.88	82:1
Orange	5.77	69:1
Gray	6.01	66:1
Light Green	7.01	57:1
Med. Green	8.06	49:1
Clear Pink	9.43	42:1
Yellow Green	11.50	35:1
Burgundy	11.93	33:1
Pale Pink	13.87	29:1
Light Blue	15.14	26:1
Dark Purple	17.88	22:1
Navy Blue	25.36	16:1
Clear Aqua	28.60	14:1
Black	50.00	8:1
No Tip Ratio Up To:		7:1

The dilution ratios above are approximate values. Due to chemical viscosity, actual dilution ratios may vary.

**FORMULA**

**GPM × 128 ÷ Desired Dilution Ratio = oz/min**

- See Unit Flow Rates chart for GPM
- Use 20 for 20:1 dilution ratio, 30 for 30:1, etc.
- Match calculated ounces per minute (oz/min) to nearest oz/min in Metering Tip Selection chart.

**UNIT FLOW RATES**

PSI	GPM
400	2.35
500	2.63
600	2.88
700	3.11
800	3.32
900	3.53
1000	3.72

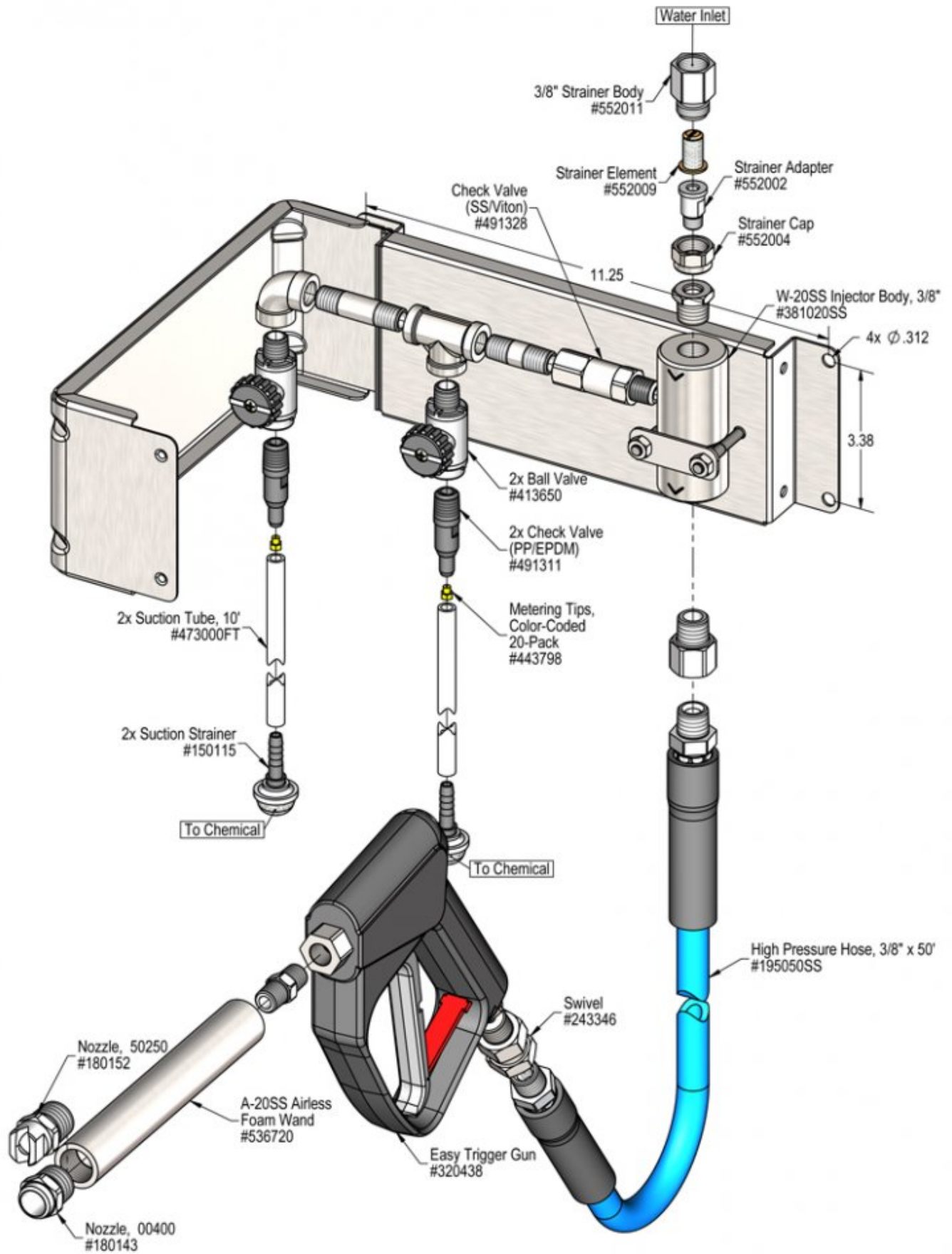

## Troubleshooting Guide

Problem	Possible Cause / Solution	
	Startup	Maintenance
A) Unit will not draw chemical	1, 5, 6, 7	10, 11, 12, 13, 14
B) Foam does not clean or foam properly	2, 4, 5, 7, 8	10, 11, 12, 13, 14
C) Using too much chemical	3	
D) Water backing up into chemical container		9

Possible Cause / Solution	
Startup	Maintenance
<ol style="list-style-type: none"> <li><b>1. Inlet ball valve not completely open</b> <ul style="list-style-type: none"> <li>◦ Completely open the ball valve.</li> </ul> </li> <li><b>2. Not enough chemical - metering tip too small</b> <ul style="list-style-type: none"> <li>◦ Install larger metering tip.</li> </ul> </li> <li><b>3. No metering tip installed or metering tip too large</b> <ul style="list-style-type: none"> <li>◦ Install smaller metering tip.</li> </ul> </li> <li><b>4. Improper chemical</b> <ul style="list-style-type: none"> <li>◦ Ensure product is recommended for foaming and the application.</li> </ul> </li> <li><b>5. Chemical tube not immersed in chemical or chemical depleted</b> <ul style="list-style-type: none"> <li>◦ Immerse tube or replenish.</li> </ul> </li> <li><b>6. Discharge hose too long or wrong size (SEE REQUIREMENTS)</b> <ul style="list-style-type: none"> <li>◦ Replace hose with correct size/length.</li> </ul> </li> <li><b>7. Water pressure or water volume too low/inlet piping too small causing poor chemical pick up</b> <ul style="list-style-type: none"> <li>◦ Increase water pressure or water volume (SEE REQUIREMENTS).</li> </ul> </li> <li><b>8. Soil has hardened on surface; always rinse before it dries</b> <ul style="list-style-type: none"> <li>◦ Reapplication may be necessary.</li> </ul> </li> </ol>	<ol style="list-style-type: none"> <li><b>9. Chemical check valve stuck or failed</b> <ul style="list-style-type: none"> <li>◦ Clean/disassemble and turn seat over or order rebuild kit.</li> </ul> </li> <li><b>10. Chemical strainer or metering tip partially blocked</b> <ul style="list-style-type: none"> <li>◦ Clean or replace chemical strainer and/or metering tip.</li> </ul> </li> <li><b>11. Chemical tube stretched out or pin hole/cut in chemical tube (sucking air in)</b> <ul style="list-style-type: none"> <li>◦ Cut off end of tube or replace tube.</li> </ul> </li> <li><b>12. Vacuum leak in chemical pick-up connections</b> <ul style="list-style-type: none"> <li>◦ Tighten the connection.</li> </ul> </li> <li><b>13. Water strainer clogged or missing/injector inlet orifice clogged</b> <ul style="list-style-type: none"> <li>◦ Clean or replace strainer; check/clean inlet orifice for obstructions. DO NOT DRILL OUT.</li> </ul> </li> <li><b>14. Hard water scale or chemical build-up may have formed in the injector body or foam wand causing poor or no chemical pick-up</b> <ul style="list-style-type: none"> <li>◦ Follow Preventive Maintenance instructions below, using hot water and/or de-scaling acid. When there is no draw at all, carefully remove fittings and soak entire injector body and/or foam wand in de-scaling acid.</li> </ul> </li> </ol>

**PREVENTIVE MAINTENANCE:** When the unit will be out of service for extended periods, place chemical tube(s) in water and flush the chemical out of the unit to help prevent chemical from drying out and causing build-up. Periodically check and clean chemical strainer and replace if missing.

