

# Pump Fed Airless Foam Wands

MODEL # 536621

## OVERVIEW

Pump Fed Airless Foam wands are designed for use with ready-to-use chemical solution supplied by a pump or central chemical feed system at 40-125 PSI. Chemical solution flows through the airless foam wand which draws in atmospheric air to create and project wet clinging foam.

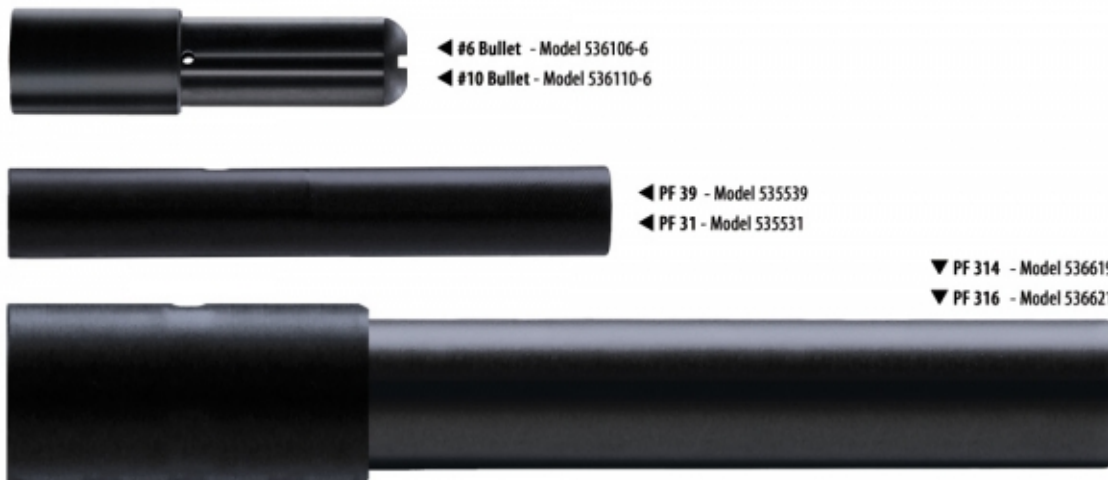

## Key Features

- No compressed air required to create clinging, wet foam
- Foaming expands the chemical, increases chemical contact time, and reduces over-application by providing visual assurance of coverage
- Machined polypropylene airless foam wands
- Available with six different flow rates to suit the requirements of the job at hand
- These wands can be used with various types of pumps:
  - Water Driven Proportioning Pump
  - Electric Pump
  - Air Operated Double Diaphragm Pump

## Bullet™ Foam Nozzles

- **#6 and #10 Bullet™ Foam Nozzles** are low-flow airless foamers that can be adjusted to project a wide angle for close-up, quick coverage or a zero degree stream for increased distance.
- The low flow rate and adjustable fan pattern makes these bullets ideal choices for conveyor belts, foam arches and bars, precision cleaning; applying degreasers and many other applications.

## Pump Fed Foam Wands

- **PF39 and PF31** are medium flow airless foam wands and project in a zero degree pattern with a usable foam throw of up to 6 feet and 8 feet, respectively, at 40 PSI solution pressure. The foam throw range increases at higher pressures. The choice of two flow rates provides efficient coverage for small or large areas.
- **PF314 and PF316** are high flow airless foam wands -- 3.8 GPM and 6.3 GPM @ 40 PSI, respectively -- and can obtain a usable foam throw of up to 20 feet when the solution pressure is optimized at about 60 PSI. The high flow rates and long range make these wands the ideal choice for super-fast coverage of large and very large areas or surfaces.

## REQUIREMENTS / SPECIFICATIONS

### Requires RTU Chemical Solution

Temperature up to 160°F  
Pressure 40-125 PSI

### Solution Flow Rate at 40 PSI

#536106-6 #6 Bullet Foam Nozzle, 1/2" FPT	0.6 GPM
#536110-6 #10 Bullet Foam Nozzle, 1/2" FPT	1.0 GPM
#535539 Wand, PP, Airless Foam, PF39	1.5 GPM
#535531 Wand, PP, Airless Foam, PF31	2.0 GPM
#536619 Wand, PP, Airless Foam, PF314	3.8 GPM
#536621 Wand, PP, Airless Foam, PF316	6.3 GPM

**Lafferty**  
EQUIPMENT MANUFACTURING INC.

1.501.851.2820 or 1.800.999.2820  
laffertyequipment.com